

OPEN_OUTDOOR COLLECTION

Varaschin®



outdoor concept

L'esterno e la natura: un caleidoscopio di colori che generano un dialogo interrotto tra design e personalità. Le mani vogliono accarezzare, gli occhi vedere e cogliere quei riferimenti del mondo outdoor in cui ci riconosciamo. Ma non solo.

La collezione outdoor seduce senza invadere, in un continuo equilibrio tra creatività colore e la ricerca della rarità. La suggestione di un intreccio, la texture di una tela, lo spessore di un legno, l'incisione di una pietra si fondono in una luce calante, o nel mare di mezzogiorno. La vasta gamma di offerta si colloca in una direzione contemporanea ricca di funzionalità silenziose, ma attente alle novità e a tutto ciò che si definisce design come laboratorio creativo.

Per noi e per la nostra cultura. Una filosofia che ci tiene in contatto con il mondo. E che rende l'esterno più bello.

Outdoor furniture and nature: a kaleidoscope of colours that provoke a dialogue between design and personality. Hands want to touch and eyes want to see and capture the elements of the outdoor world we recognize. But not only.

Our outdoor collection seduces without intruding, in a continuous balancing act of creativity, colour and a search for rarity. The evocation of a weave, the texture of a fabric, the thickness of wood and an engraving on a stone come together in the dusk or the mid-day sea. Our wide range of products goes in a contemporary direction and is rich in discreet functionality, but at the same time pays attention to novelty and everything that can be defined as design and used as a creative workshop.

This is a philosophy that keeps us and our culture constantly in touch with the world. And enhances the attraction of the outdoors.

designer



Le linee classiche dei suoi pezzi evidenziano la formazione del designer maltese, per anni collaboratore di importanti studi di architettura. La sua mano delicata e versatile porta nei diversi progetti un tocco discreto ed elegante tipico del grande design internazionale.

The classical lines of his pieces testify to this Maltese designer's training gained in important architect's studios. His delicate versatile hand lends his projects the discerning elegant touch typical of great international design.

[GORDON GUILLAUMIER]



Dai maestri del passato hanno imparato che architetto e designer sono due professioni indissolubili: dai progetti su larga scala, agli allestimenti e ai più piccoli oggetti, Calvi e Brambilla amano sperimentare con rimandi alla classicità e una grande attenzione verso le ultime innovazioni tecnologiche.

The masters of the past have taught them that architect and designer are two inseparable professions: from large-scale projects to creating ambiances and the smallest objects, Calvi and Brambilla love experimenting with one eye on classics and careful attention paid to the latest technological innovations.

[CALVI & BRAMBILLA]



I suoi prodotti si ispirano alle curve sensuali del corpo umano, fluide e ironiche. Coates è un artista a tutt'oggi: architetto, designer, curatore e insegnante è uno di quelli, la cui visione si basa sullo spazio tra i vari campi visivi; un raro talento la cui visione artistica deriva dalla sovrapposizione di diversi ambiti professionali.

His products are inspired by the human body's sensual curves, fluid and ironic. Coates is an all-round artist: architect, designer, curator and teacher, his vision is based on the spaces between the different fields of view; a rare talent whose artistic perspective derives from superimposing the influence of several professions.

[NIGEL COATES]



Ha studiato Disegno Industriale presso l'Università di Wuppertal. Ha collaborato con alcuni stilisti come Babel Progettazione e Moll Design. In seguito ha lavorato in 10 anni come capo dello sviluppo e della progettazione per la fabbrica di mobili Reinhard AG Sachseln. Nel 2006 ha fondato rabadesign e il 2009 rabadesign GmbH Svizzera.

He studied Industrial Design at the University of Wuppertal. He collaborated with some designers like Babel Design and Moll Design. Following He worked within 10 years as the head of development and design for the furniture factory Reinhard AG Sachseln. In the year 2006 he founded rabadesign and 2009 rabadesign GmbH of Switzerland.

[RAINER BACHSCHMID]



Fa parte di quella generazione di architetti italiani caratterizzata da una formazione sia architettonica sia di design e maturata collaborando con i maestri del design italiano. I numerosi premi internazionali ricevuti per opere in queste discipline sono la conferma della qualità espressa. È sempre stato un progettista curioso e questo lo ha portato ad aprire percorsi con nuove opportunità linguistiche.

He is part of that generation of Italian architects who have developed their expertise in the hands of the Masters of Italian design working both on structural architecture and contemporary design. The numerous International Awards he has received are proof of his innate architectural qualities. He has always differed from his colleagues and this has led him to follow different architectural expressions.

[MARIO MAZZER]



Nato nel 1942 a Roma, si laurea in architettura nel 1968. Da diversi anni opera in Italia, con incarichi di progettazione architettonica e di Interior Design. In particolare si dedica a strutture alberghiere e ricettive che hanno riscosso e riscuotono tuttora grande successo e riconoscimento.

Born in Rome in 1942, he graduated in Architecture in 1968. He has been working in Italy for several years, dealing with architectural projects and interior design. In particular he dedicates his talents to hotels and hospitality structures, which have always achieved great success and acknowledgement.

[LORENZO BELLINI]



Tra i più importanti designer francesi della sua generazione, fonde ispirazioni tratte da elementi naturali e quelle tratte dall'immaginario degli anni '60. È un sostenitore del fatto che il design sia inevitabilmente destinato a un pubblico mainstream e che il designer non è uno specialista di oggetti quanto di una maniera di vita.

One of the most important French designers of his generation, he combines inspiration from natural elements with the icons of the 60s. He upholds that the inevitable destination of design is the mainstream public and that designers are not specialists in objects, but rather in a way of living.

[CHRISTOPHE PILLET]

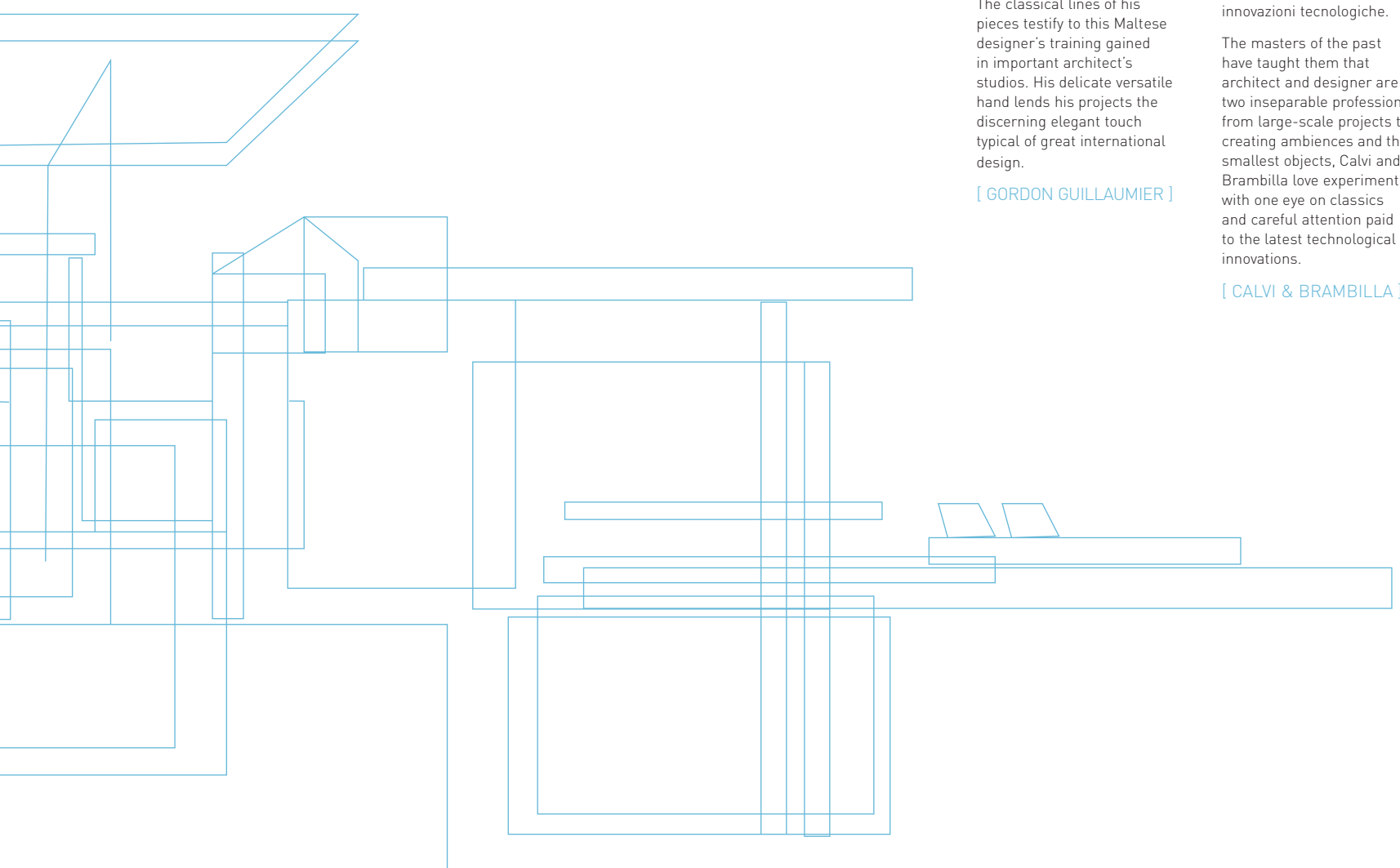

INDICE INDEX

ALTEA_102
ARENA_124
AVALON_080
CAFENOIR_136
CAFEPLAYA_142
CORA_148

DOLMEN_044
DOMINO_130
GARDENIA_156
GIADA_188
KELLY_194
KRESOS_200
LOOP_056
LOTUS_170
MARINE_070
PISOLO_164
PLAZA_034
ROLLOVER_096
TIBET_052
TONKINO_090
TULIP_206

VICTOR_008
OMBRELLONI
& GAZEBO_212
BASI TAVOLI_222

+

ACCESSORI_241
SCHEDE TECNICHE_246

DESIGN

R&S VARASCHIN

victor

Collezione con struttura in alluminio, sedute e schienali in tessuto traforato batyline, differenti cromie.

Collection with aluminium frame, seat and backrest in batyline in different colours.

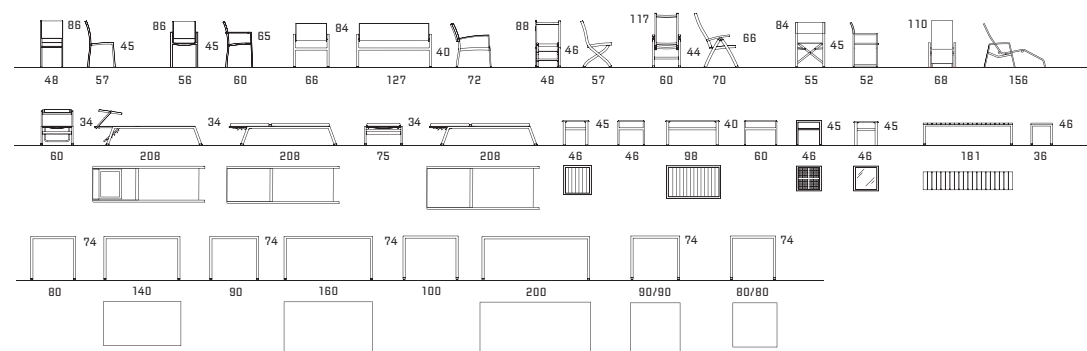







victor
014

victor
015





victor
018



victor
019







victor
024



victor
025







victor
030



victor
031



victor
032

victor
033

DESIGN

GORDON GUILLAUMIER

plaza

Tavoli in alluminio verniciato con top a doghe e bordo perimetrale in alluminio anodizzato.

Varnished aluminium tables with slatted top and perimeter aluminium edges.

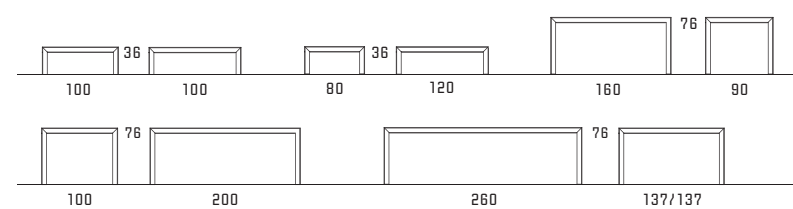









DESIGN

R&S VARASCHIN

dolmen

Tavolo allungabile con struttura in alluminio verniciato, piano in hpl.

Extendable table with varnished aluminium structure, hpl top.

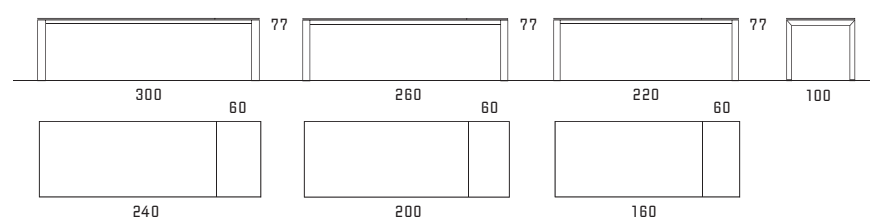





dolmen
048

dolmen
049



DESIGN

R&S VARASCHIN

tibet

Tavolo con struttura
in acciaio 304 e teak a doghe.

Table with stainless steel 304
frame and slatted teak top.

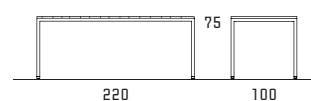

052





DESIGN

NIGEL COATES

loop

Collezione intrecciata a mano in fibra sintetica, struttura tondino sagomato di acciaio 304 EP e pulito elettronicamente. Fioraie con struttura in alluminio.

Collection of hand-woven synthetic fiber, rod-shaped structure of steel 304 EP electronically and clean. Fioraie with aluminum.

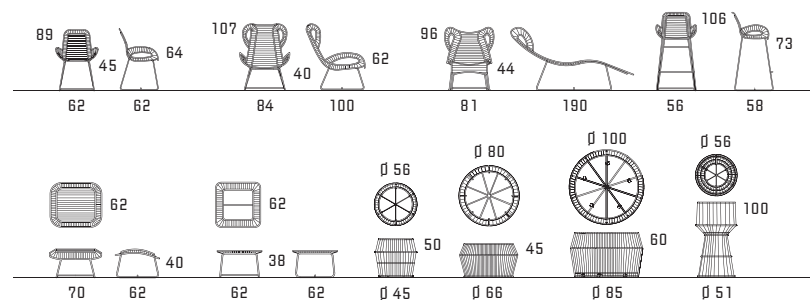



loop
058

loop
059



loop
060

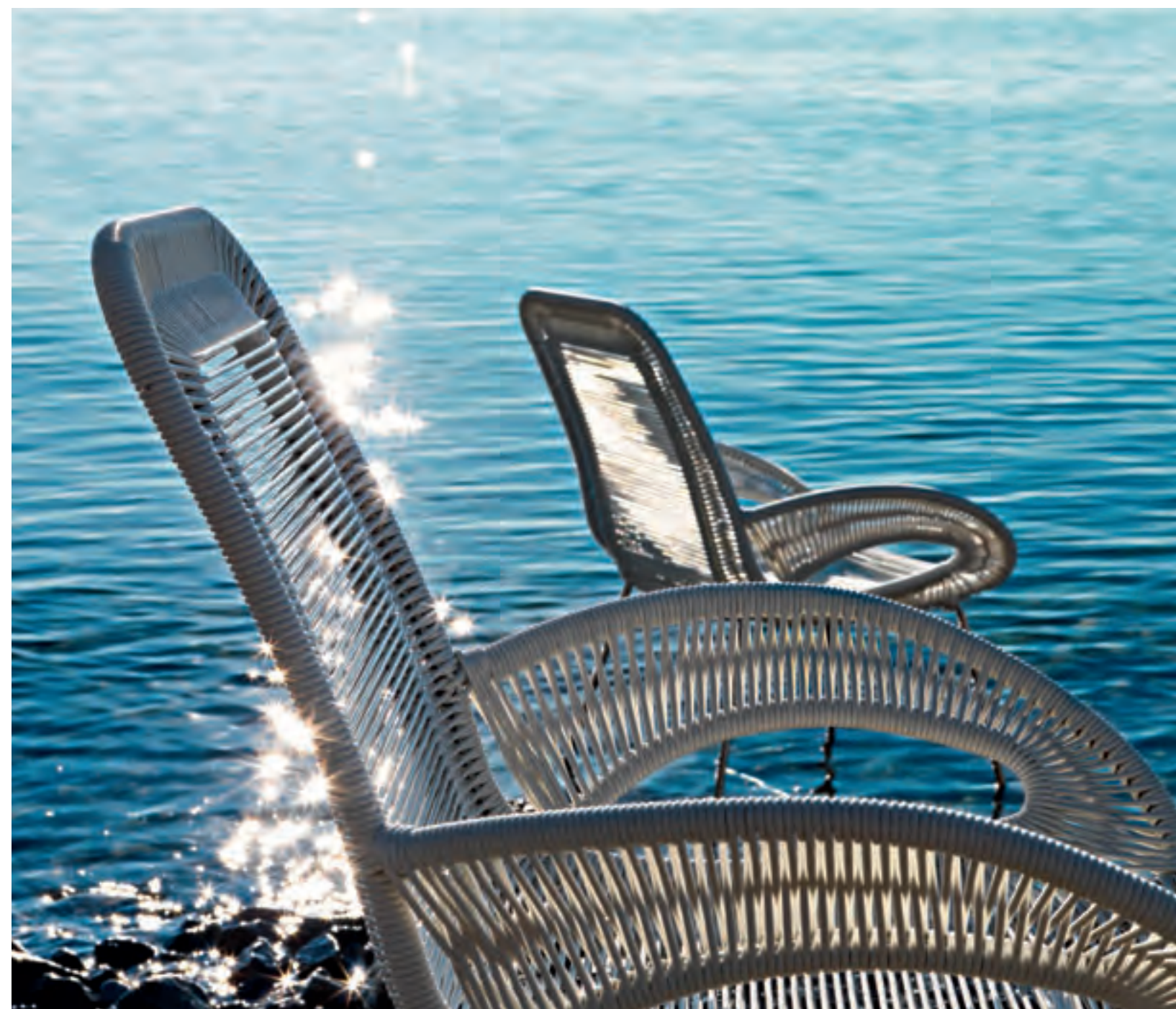

loop
061









DESIGN

MARIO MAZZER

marine

Collezione intrecciata a mano in fibra sintetica, struttura in tubo sagomato di acciaio inox aisi 316L.

Collection in hand woven man-made fibre, frame in shaped aisi 316L stainless steel tube.

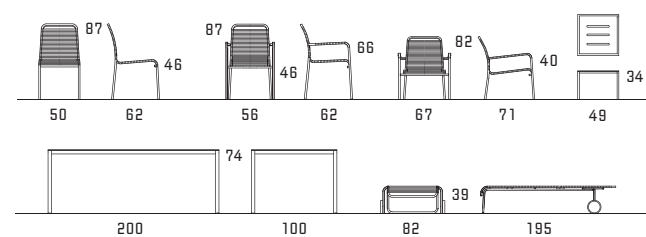





074 marine

075 marine





DESIGN

CALVI & BRAMBILLA

avalon

Collezione intrecciata a mano
in fibra sintetica con struttura
in tondino di acciaio inox aisi 304EP.

collection with frame in aisi 304EP stainless
steel rod and hand woven man-made fibre.







084 avalon

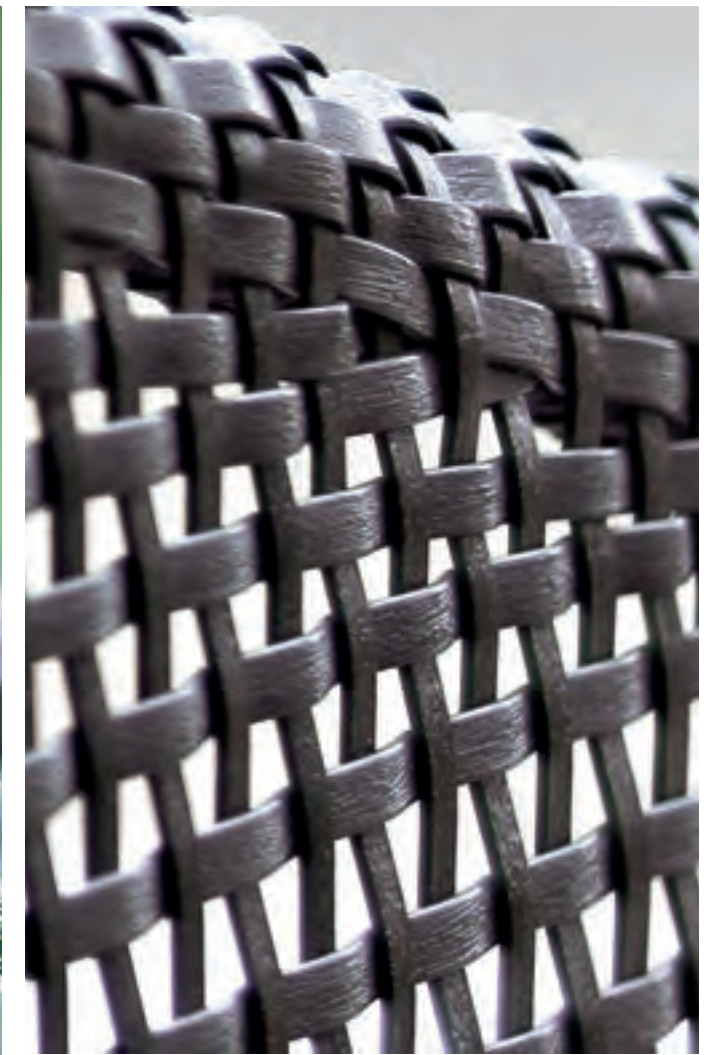

085 avalon





DESIGN

R&S VARASCHIN

tonkino

Collezione intrecciata a mano
in fibra sintetica con intelaiatura
in alluminio verniciato.

Collection with aluminium frame
and hand woven man-made fibre.

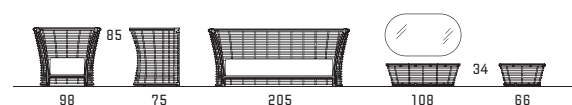





DESIGN

NIGEL COATES

rollover

Collezione intrecciata a mano
in fibra sintetica con intelaiatura
in alluminio verniciato.

Collection with aluminium frame
and hand woven man-made fibre.

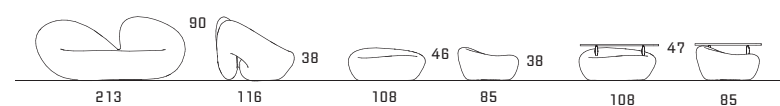





DESIGN

R&S VARASCHIN

altea

Collezione intrecciata a mano con intelaiatura in tubo di alluminio e fibra sintetica a motivo floreale.

Hand woven collection, aluminium frame and man-made fibre weaving with floral motif.

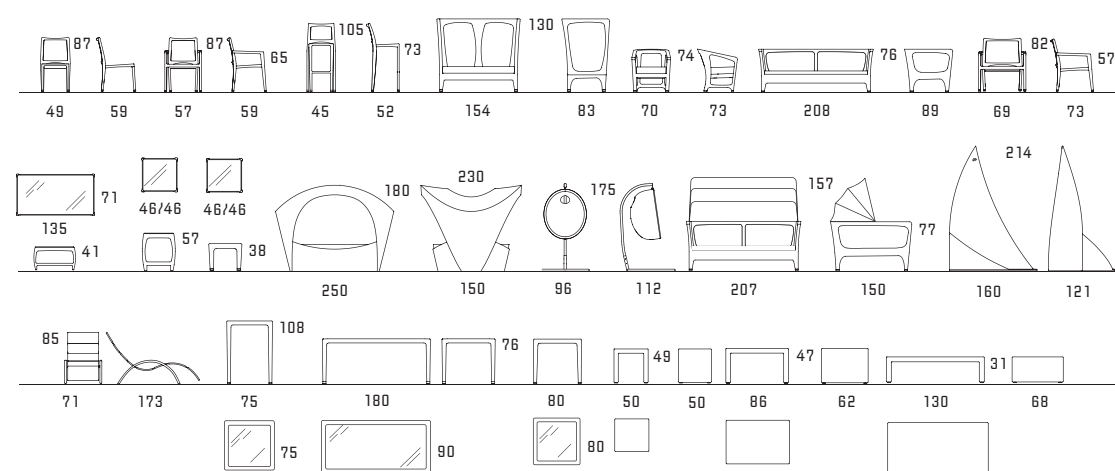











altea





altea
116



altea
117

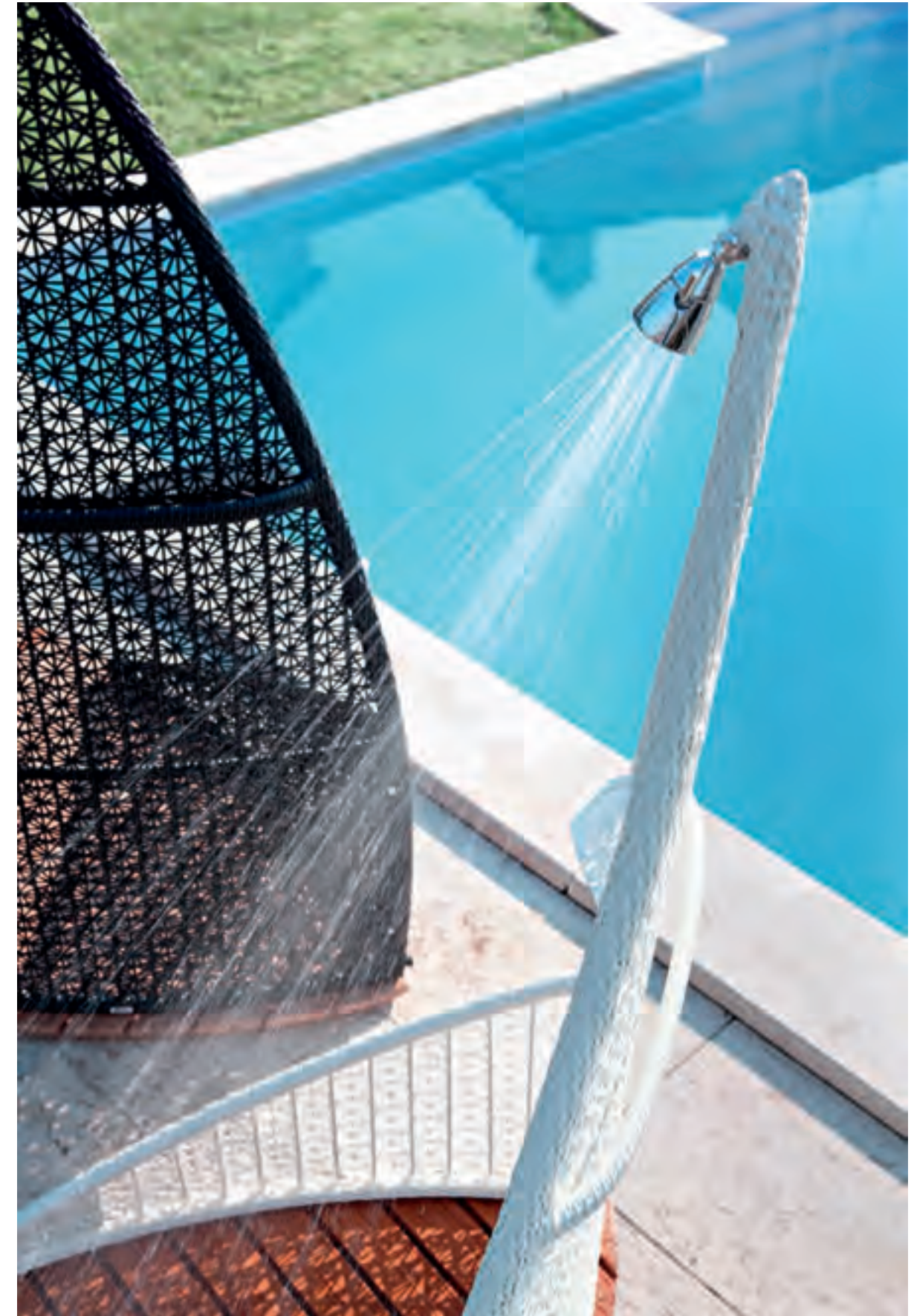





DESIGN

R&S VARASCHIN

arena

Collezione intrecciata a mano
in fibra sintetica con intelaiatura
in alluminio verniciato.

Collection with aluminium frame
and hand woven man-made fibre.

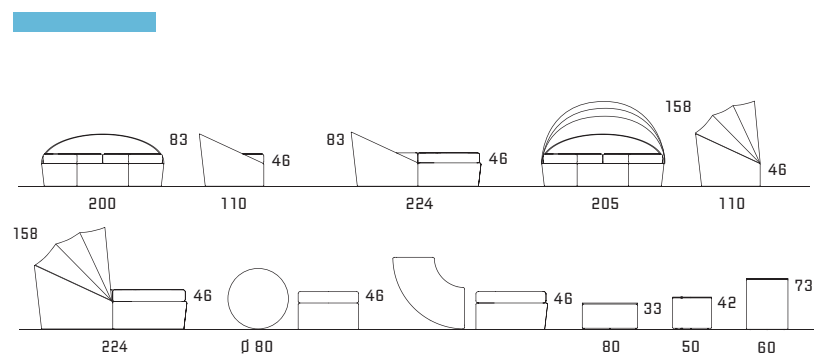





DESIGN

R&S VARASCHIN

domino

Collezione in fibra sintetica
intrecciata a mano con
intelaiatura in alluminio
verniciato.

Collection with aluminium frame
and hand woven man-made fibre.

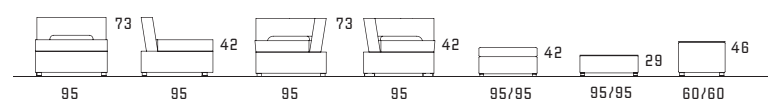

130







domino
134

domino
135

DESIGN

R&S VARASCHIN

cafenoir

Seduta intrecciata a mano in
fibra sintetica con intelaiatura
in alluminio verniciato.

Chair with aluminium frame
and hand woven man-made fibre.

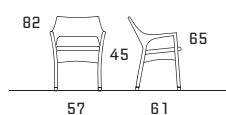

136







DESIGN

R&S VARASCHIN

cafeplaya

Seduta intrecciata a mano in fibra sintetica con intelaiatura in alluminio verniciato.

Chairs with aluminium frame and hand woven man-made fibre.

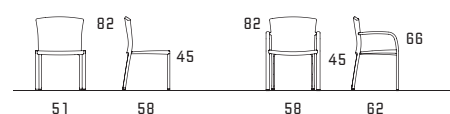

142







DESIGN

R&S VARASCHIN

cora

Collezione intrecciata a mano
in fibra sintetica con intelaiatura
in alluminio verniciato.

Collection with aluminium frame
and hand woven man-made fibre.

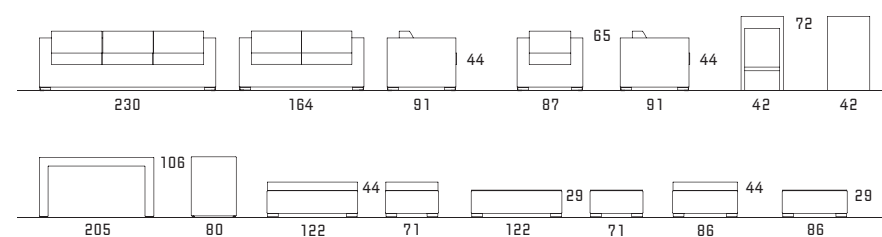







DESIGN

R&S VARASCHIN

gardenia

Collezione in fibra sintetica
intrecciata a mano con
intelaiatura in alluminio
verniciato.

Collection with aluminium frame
and hand woven man-made fibre.

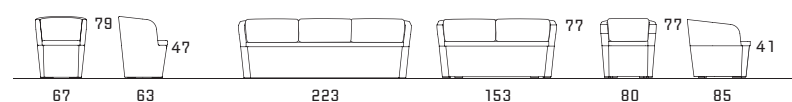





gardenia
160



gardenia
161



DESIGN

R&S VARASCHIN

pisolo

Lettini intrecciati a mano in
fibra sintetica con intelaiatura
in alluminio verniciato.

Sunbeds with aluminium frame
and hand woven man-made fibre.

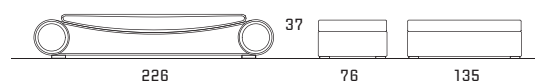





DESIGN

R&S VARASCHIN

lotus

Collezione intrecciata a mano
in fibra sintetica con intelaiatura
in alluminio verniciato.

Collection with aluminium frame
and hand woven man-made fibre.

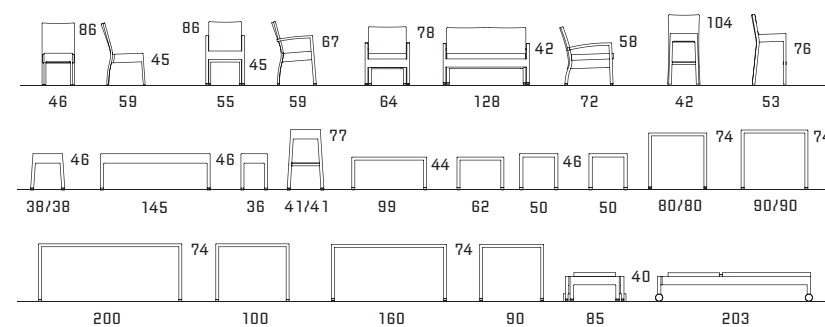

170









lotus
178

lotus
179









DESIGN

R&S VARASCHIN

giada

Collezione intrecciata a mano
in fibra sintetica con intelaiatura
in alluminio verniciato.

Collection with aluminium frame
and hand woven man-made fibre.

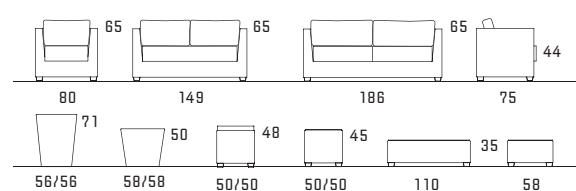





DESIGN

R&S VARASCHIN

kelly

Sedute in fibra sintetica intrecciata a mano con intelaiatura in alluminio verniciato.

Chairs with aluminium frame and hand woven man-made fibre.

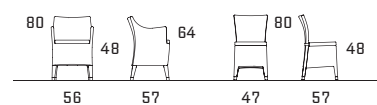



196 ^{kelly}

197 ^{kelly}



DESIGN

R&S VARASCHIN

kresos

Collezione intrecciata a mano
in fibra sintetica con intelaiatura
in alluminio verniciato.

Collection with aluminium frame
and hand woven man-made fibre.

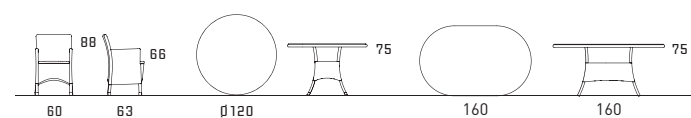





DESIGN

R&S VARASCHIN

tulip

Collezione intrecciata a mano
in fibra sintetica con intelaiatura
in alluminio verniciato.

Collection with aluminium frame
and hand woven man-made fibre.

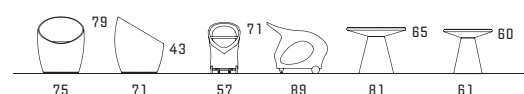





210 tulip



211 tulip

DESIGN

R&S VARASCHIN

ombrelloni & gazebo

Linea di coperture per esterno smontabili, teli in tessuto idrorepellente bianco e basamento in lastroni di marmo.

Pavilion è un gazebo con struttura portante realizzata in alluminio, completa di pavimento a doghe, celini frangisole, angolo privacy e 4 tende verticali di chiusura.

Line of knockdown outdoor sun-umbrellas. White waterproof canvas canopy and marble slab base.

Pavilion with aluminium supporting structure, slatted floor, sun coverings, privacy corner and 4 side curtains.

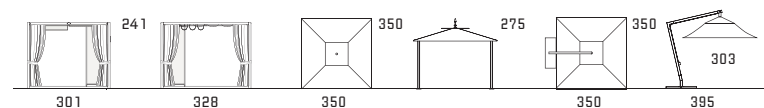



214 pavilion



215 pavilion



216 pavilion



217 pavilion





DESIGN

R&S VARASCHIN

lotus table bases

Collezione di basi tavolo realizzata in alluminio anodizzato, in tubo e trafilati pieni di diverse sezioni. Finitura stelo con intreccio di fibra sintetica. adatto per uso esterno, anche in zone ad alta intensità marina.

Table base collection in anodized aluminium, tube and full drawn pieces in different sections. Central leg with synthetic fibre weaving. Suitable for outdoor use also in marine environments with high concentration of saline mist.

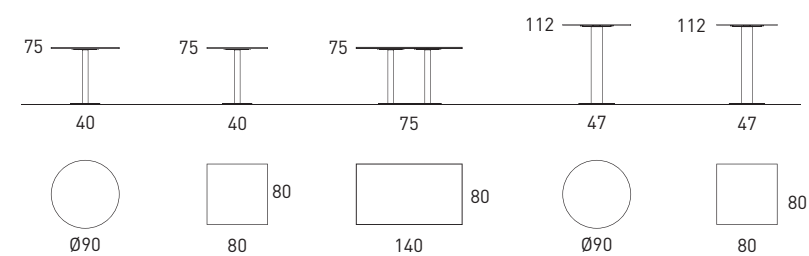



DESIGN

R&S VARASCHIN

metro table bases

Collezione di basi tavolo realizzata in alluminio anodizzato, in tubo e trafilati pieni di diverse sezioni. Adatto per uso esterno, anche in zone ad alta intensità marina.

Table base collection in anodized aluminium, tube and full drawn pieces in different sections. Suitable for outdoor use also in marine environments with high concentration of saline mist.

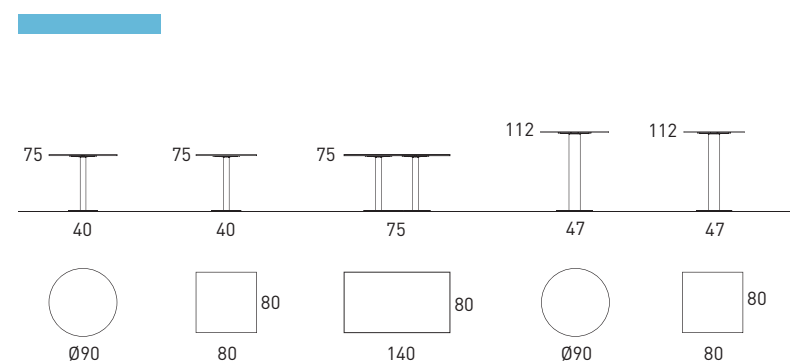

DESIGN

RAINER BACHSCHMID

victor table bases

Collezione di basi tavolo realizzata in alluminio anodizzato o verniciato a polveri, in tubo e trafilati pieni di diverse sezioni. Appoggio a terra con quattro razze di forte spessore. adatto per uso esterno, anche in zone ad alta intensità marina.

Four spoke table base collection in anodized aluminium, tube and full drawn pieces in different sections. Suitable for outdoor use also in marine environments with high concentration of saline mist.

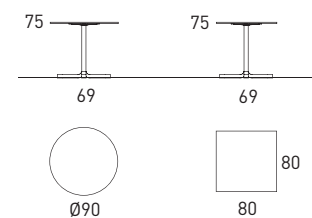



DESIGN

LORENZO BELLINI

tuxedo table bases

Base tavolo realizzata in ferro, in tubo e trafilati pieni di diverse sezioni. Trattata con cataforesi per la massima protezione in ambienti esterni. Finitura a polveri in diverse colorazioni.

Table base in steel rod and flat steel wire in different sections. Cataphoresis treated for maximum protection outdoors. Powder coated in different colours.

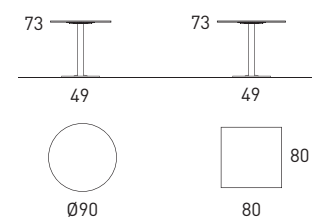

232



233

DESIGN

R&S VARASCHIN

big table bases

Base tavolo realizzata in ferro, in tubo e trafilati pieni di diverse sezioni. Trattata con cataforesi per la massima protezione in ambienti esterni. Finitura a polveri in diverse colorazioni. Per solo uso interno, disponibile anche in versione cromata.

Table base in steel rod and flat steel wire in different sections. Cathaphoresis treated for maximum protection outdoors. Powder coated in different colours. Only for indoor use, available also in the chromed version.

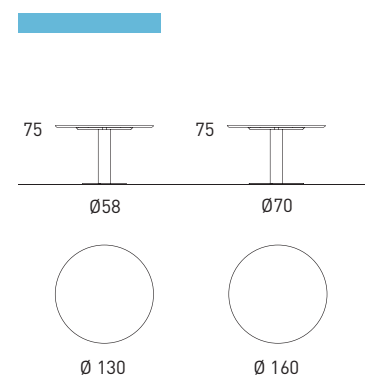

234



235

DESIGN

CHRISTOPHE PILLET

summer set table bases

Collezione di basi tavolo realizzata in ferro, in tubo e trafilati pieni di diverse sezioni. Trattata con ciclo C5m per la massima protezione anche in zone ad alta intensita' salina. Finitura a polveri in diverse colorazioni. Per solo uso interno, disponibile anche in versione cromata.

Table base collection in steel rod and flat steel wire in different sections. Treated with C5m cycle for maximum protection also in marine environments with high concentration of saline mist. Powder coated in different colours. Only for indoor use, available also in the chromed version.

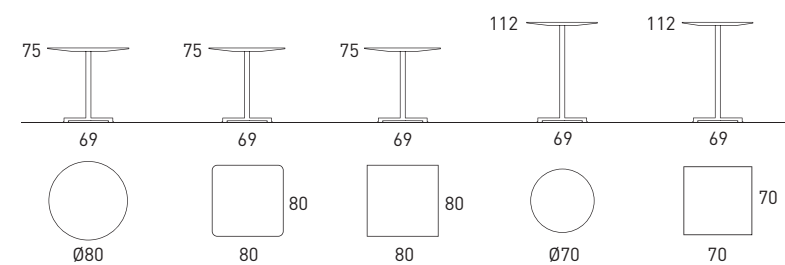



summer set
238



summer set
239



ACCESSORI
ACCESSORIES

TELI DI COPERTURA / TARPAULINS

Teli di copertura in poliestere termosaldato per protezione raggi solari ed agenti atmosferici con coulisse di tensionamento alla base.

Polyester thermo joined tarpaulins for sun rays and atmospheric agents protection.



Rotondo

	h	Cod.		
230	90	9430	tavoli + sedie + arena semicircolare	140x100 + sedie 160x100 + sedie
160	90	9420	tavoli quadri o rotondi con sedie + nido	90x90 + sedie



L	P	h	Cod.		
290	140	90	9436	tavoli + sedie	280x100 + sedie
230	130	90	9435	tavoli + sedie	220x100 + sedie
235	95	80	9470	divano 2-3 posti	
175	95	80	9460	divano 2 posti	
220	80	55	9401	lettini - sdraio	
100	90	130	9480	poltrona tibidabo alta	
200	90	130	9485	divano tibidabo alto	
135	72	40	9443	tavolini rettangolari cora + giada	



Pila

L	P	h	Cod.	
110	60	200	9455	n. 10 sedie poltroncine
90	60	140	9454	n. 6 sedie poltroncine



Quadro

L	P	h	Cod.	
100	100	80	9451	poltrone
70	70	80	9450	poltroncine / carrelli / tavolini
73	73	33	9441	tavolini babylon / kente
50	50	50	9442	tavolini piccoli giada / lotus / victor
103	103	33	9440	tavolini babylon / kente grid / summer set / cora



MANUTENZIONE / MAINTENANCE

TEAK CLEANER

Un unico prodotto per pulire e lucidare. Per pulire e ripristinare il teak scolorito, sporco, di colore grigio e/o verde.

Cleaner and brightener in one. To clean and restore discoloured, dirty, dark grey and/or green teak.



TEAK PROTECTOR

Per mantenere il colore originale marrone dorato del teak per un lungo periodo:
- fino a 4 volte più a lungo dell'olio per teak.
- fino a 2 volte più a lungo del sigillante per teak.

To maintain the original, golden-brown colour of teak for a long time:
- up to 4 times longer than teak-oil
- up to twice as long as teak sealers.



GLASS CLEANER

Toglie lo sporco, l'umidità e i piccoli graffi. Per dare al vetro un nuovo aspetto.

Removes dirt, moisture and small scratches. Restores the new look.



GLASS PROTECTOR

Protegge e lo rende repellente allo sporco e all'acqua. Mantiene il vetro pulito e nuovo per un lungo periodo.

Protects and is dirt/water repellent. Maintains the new look for a long, long time.



CLEANER

Pulisce e ristabilisce l'aspetto nuovo del metallo.

Removes dirt and moisture and restores the new look.



WAXPOLISH

Protegge e lo rende repellente allo sporco e all'acqua. Mantiene l'aspetto originale del metallo per un lungo periodo.

Protects and is dirt/water repellent. Maintains the new look for a long, long time.



CLEANER

Detergente non schiumoso per rivestimenti di sedute e schienali.

Non foaming cleaner for seatings and back covers.



CLEANER FOR WOEVENS

Un detergente speciale non schiumoso per intrecci in fibra sintetica.

A special non-foaming cleaner for synthetic fibres wovens.



Golden Care
CLEANS, RESTORES & PROTECTS

SEZIONE TECNICA
TECHNICAL SECTION



SEDIE / CHAIRS



altea
cod. 2859
bronzo / moka / bianco
bronze / dark brown / white



avalon
cod. 2884
moka / dark brown
inox 304EP
stainless steel 304EP



cafeplaya
cod. 2857
bianco / moka
white / dark brown



kelly
cod. 2900
bianco / corda / moka
white / silk grey / dark brown



lotus
cod. 2816
bianco / corda / moka / naturale / bronzo
white / silk grey / dark brown / natural / bronze



marine
cod. 2888
bianco / nero
white / black
AISI 316L
stainless steel AISI 316L



victor
cod. 2911T
struttura bianco lucido / moka gofrato / grigio opaco
structure glossy white / mat dark brown / mat grey
batyline moka / grigio / turchese / nero
batyline dark brown / grey / cyan / black
tessuti resistenti alla tensione
fabrics resilient to tension



victor
cod. 2901T
struttura bianco lucido / moka gofrato grigio opaco
structure glossy white / mat dark brown / mat grey
batyline bianco / moka / grigio / turchese / nero
batyline white / dark brown / grey / cyan / black

SEDIE / CHAIRS



victor
cod. 2905T
struttura bianco lucido
structure glossy white
batyline bianco / white batyline

POLTRONCINE / CHAIRS



altea
cod. 2862
bronzo / moka / bianco
bronze / dark brown / white



avalon
cod. 2885
moka / dark brown
inox 304EP
stainless steel 304EP



cafenoir
cod. 2853
bianco / moka / corda
white / dark brown / silk grey



cafeplaya
cod. 2858
bianco / moka
white / dark brown

POLTRONCINE / CHAIRS



gardenia
cod. 2873
bronzo / moka / bianco
bronze / dark brown / white



kelly
cod. 2894
bianco / white



kresos
cod. 2815
bianco / corda / moka / bronzo
white / silk grey / dark brown / bronze



loop
cod. 2863
bianco / nero
white / black
inox 304EP
stainless steel 304EP



lotus
cod. 2817
bianco / corda / moka / bronzo
white / silk grey / dark brown / bronze



marine
cod. 2889
bianco / nero
white / black
AISI 316L
stainless steel AISI 316L



tulip
cod. 2868
bianco / moka / bronzo
white / dark brown / bronze



victor
cod. 2902T
struttura bianco lucido / moka goffrato / grigio opaco
structure glossy white / mat dark brown / mat grey
batyline bianco / moka / grigio / nero / turchese
batyline white / dark brown / grey / black / cyan

POLTRONCINE / CHAIRS



victor
cod. 2906T
struttura bianco lucido
structure glossy white
batyline bianco
batyline white

SGABELLI / STOOLS



altea
cod. 2866
bronzo / moka / bianco
bronze / dark brown / white



cora
cod. 2811
bianco / moka
white / dark brown



loop
cod. 2875
bianco / nero
white / black
inox 304EP
stainless steel 304EP



lotus
cod. 2804
moka / naturale
dark brown / natural

SGABELLI / STOOLS



lotus
cod. 2880
moka / bianco / corda
dark brown / white / silk grey

POLTRONE / ARMCHAIRS



altea
cod. 1059
bianco / moka / bronzo
white / dark brown / bronze



altea lounge
cod. 2867
bronzo / moka
bronze / dark brown



avalon lounge
cod. 2886
moka / dark brown / inox 304EP
stainless steel 304EP



cora
cod. 1048
bianco / moka / corda
white / dark brown / silk grey

POLTRONE / ARMCHAIRS



domino
cod. 1050
bianco / moka
white / dark brown



domino angolo
cod. 1051
bianco / moka
white / dark brown



gardenia
cod. 1056
bianco / bronzo / moka
white / bronze / dark brown



giada
cod. 1047
bianco / moka
white / dark brown



loop
cod. 2864
bianco / nero / inox 304EP
white / black
stainless steel 304EP



lotus
cod. 2850
moka / corda / bianco
dark brown / silk grey / white



marine lounge
cod. 2890
bianco / nero / AISI 316L
white / black
stainless steel AISI 316L



tonkino
cod. 1950
corda / silk grey

POLTRONE / ARMCHAIRS



victor
cod. 2907T
struttura bianco lucido
structure glossy white
batyline bianco / batyline white

DIVANI / SOFAS



altea
cod. 1427
bronzo / moka / bianco
bronze / dark brown / white



altea
cod. 3963
bronzo / moka / bianco
bronze / dark brown / white



altea
cod. 3265
bianco / bronzo / moka
white / bronze / dark brown



arena
cod. 1617
moka / dark brown
bianco / white

DIVANI / SOFAS



arena
cod. 1618
moka / dark brown
bianco / white



arena
cod. 1622
moka / dark brown
bianco / white



cora
cod. 1426
bianco / moka / corda
white / dark brown
silk brown



gardenia
cod. 1428
bronzo / moka / bianco
bronze / dark brown
white



arena
cod. 1621
moka / dark brown
bianco / white



cora
cod. 1240
bianco / moka / corda
white / dark brown / silk grey



gardenia
cod. 1243
bronzo / moka / bianco
bronze / dark brown
white



giada
cod. 1239
bianco / moka
white / dark brown

DIVANI / SOFAS



giada
cod. 1429
bianco / moka
white / dark brown



lotus
cod. 2851
moka / corda / bianco
dark brown / silk grey
white



rollover
cod. 1242
moka / dark brown



tonkino
cod. 1951
corda / silk grey

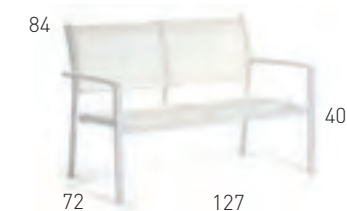

victor
cod. 2908T
struttura bianco lucido
structure glossy white
batyline bianco / batyline white

TAVOLINI / COFFEE TABLES



altea
cod. 3098
bianco / bronzo / moka
white / bronze / dark brown



altea
cod. 3099
bianco / bronzo / moka
white / bronze / dark brown



altea
cod. 3972
bianco / bronzo / moka
white / bronze / dark brown



altea
cod. 3115
bianco / bronzo / moka
white / bronze / dark brown



altea
cod. 3116
bianco / bronzo / moka
white / bronze / dark brown



altea
cod. 3117
bianco / bronzo / moka
white / bronze / dark brown



arena
cod. 3091
bianco / bronzo / moka
white / bronze / dark brown
top in vetro trasparente
trasparent glass top



arena
cod. 3880
bianco / moka
white / dark brown

TAVOLINI / COFFEE TABLES



arena
cod. 3092
bianco / moka
white / dark brown

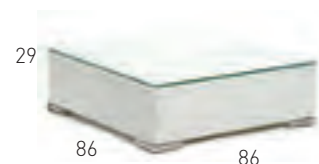

cora
cod. 3083
moka / bianco / corda
dark brown / white / silk grey

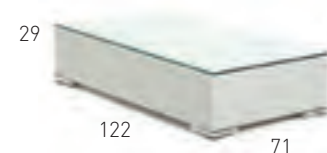

cora
cod. 3084
moka / bianco / corda
dark brown / white / silk grey

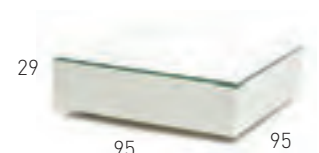

domino
cod. 3090
bianco / moka
white / dark brown



domino
cod. 3097
bianco / moka
white / dark brown



giada
cod. 3082
moka / bianco
dark brown / white

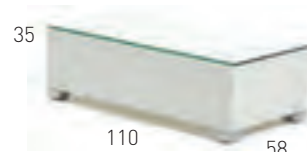

giada
cod. 3085
moka / bianco
dark brown / white



loop
cod. 3967
bianco / nero
white / black
top in vetro trasparente
trasparent glass top
inox 304EP
stainless steel 304EP

TAVOLINI / COFFEE TABLES



lotus
cod. 2803
moka / bianco / corda / naturale / bronzo
dark brown / white / silk grey / natural / bronze



lotus
cod. 3975
moka / bianco / corda / bronzo
dark brown / white / silk grey / bronze
top in vetro opalino
opal glass top



lotus
cod. 3976
moka / bianco / corda
dark brown / white / silk grey
top in vetro opalino
opal glass top



marine
cod. 3078
inox aisi 316L
aisi 316L stainless steel
top in hpl bianco o nero
hpl top white or black



plaza
cod. 3094
bianco lucido
glossy white



plaza
cod. 3095
bianco lucido
glossy white



rollover
cod. 3096
moka / dark brown
top in vetro trasparente
trasparent glass top

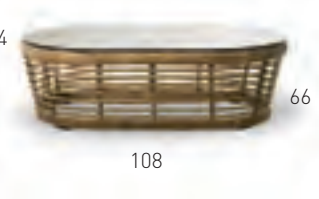

tonkino
cod. 1955
corda / silk grey

TAVOLINI / COFFEE TABLES



victor
cod. **3958**
bianco lucido / glossy white
piano in polarwood
polarwood top



victor
cod. **3964**
bianco lucido / glossy white
piano alluminio bianco
white aluminium slats



victor
cod. **3965**
bianco lucido / glossy white
piano alluminio bianco
white aluminium slats



victor
cod. **3974**
bianco lucido / moka goffrato / grigio opaco
glossy white / mat dark brown / mat grey
piano forato / pierced top



victor
cod. **3977**
bianco lucido / glossy white
top in vetro / glass top



altea
cod. **3864**
bianco / bronzo / moka
white / bronze / dark brown



altea
cod. **3885**
bianco / bronzo / moka
white / bronze / dark brown



altea
cod. **3891**
bianco / bronzo / moka
white / bronze / dark brown



dolmen
cod. **1820H**
bianco lucido / grigio opaco
glossy white / mat grey
top hpl bianco / quarzo goffrato
hpl top white / quartz micaceous

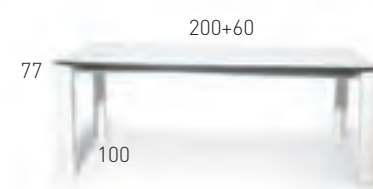

dolmen
cod. **1821H**
bianco lucido / grigio opaco
glossy white / mat grey
top hpl bianco / quarzo goffrato
hpl top white / quartz micaceous

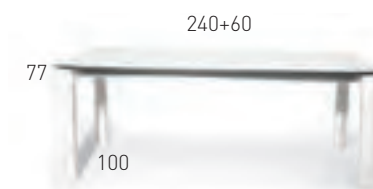

dolmen
cod. **1822H**
bianco lucido / grigio opaco
glossy white / mat grey
top hpl bianco / quarzo goffrato
hpl top white / quartz micaceous



kresos
cod. **3829**
moka / bianco / naturale
dark brown / white / natural



kresos
cod. **3830**
naturale / moka
natural / dark brown
top teak / teak top

TAVOLI / TABLES



kresos
cod. 3833
naturale / natural
top teak / teak top



lotus
cod. 3840
moka / bianco
bronzo / corda
dark brown / white
bronze / silk grey



plaza
cod. 3873
bianco lucido / grigio opaco
moka goffrato
glossy white / mat grey
mat dark brown



plaza
cod. 3877
bianco lucido / moka goffrato
glossy white / mat dark brown



lotus
cod. 3886
bianco / moka / corda
white / dark brown / silk grey



lotus
cod. 3894
bianco / moka
bronzo / corda
white / dark brown
bronze / silk grey



plaza
cod. 3878
bianco lucido / glossy white
moka goffrato / mat dark brown
grigio opaco / mat grey



plaza
cod. 3879
bianco lucido / glossy white
moka goffrato / mat dark brown
grigio opaco / mat grey



lotus
cod. 3895
bianco / moka
bronzo / corda
white / dark brown
bronze / silk grey



lotus
cod. 3861
naturale / natural
top vetro / glass top



summerset
cod. 3130
struttura bianco / moka / grigio / ciano
structure white / moka / grey / cyan
top hpl
hpl top



summerset
cod. 3131
struttura bianco / moka / grigio / ciano
structure white / moka / grey / cyan
top marmo
hpl marble



marine
cod. 3843
inox 304 / stainless steel 304
top hpl bianco o quarzo goffrato
hpl top white or quartz micaceous



plaza
cod. 3825
bianco lucido / grigio opaco
moka goffrato
glossy white / mat grey
dark brown micaceous



summerset
cod. 3132
struttura bianco / moka / grigio
structure white / moka / grey
top hpl / marmo
hpl top / marble



summerset
cod. 3120
struttura bianco / moka / grigio / ciano
structure white / moka / grey / cyan
top marmo
hpl marble

TAVOLI / TABLES



summerset
cod. 3119 / 3129
struttura bianco / moka / grigio / ciano
structure white / moka / grey / cyan
top vari
various top



summerset
cod. 3128
struttura bianco / moka / grigio / ciano
structure white / moka / grey / cyan
top vari
various top



tibet
cod. 3846
inox satinato e teak
brushed stainless steel and teak



tulip
cod. 3887
bianco / bronzo / moka
white / bronze / dark brown



tulip
cod. 3959
bianco / moka / bronzo
white / dark brown / bronze

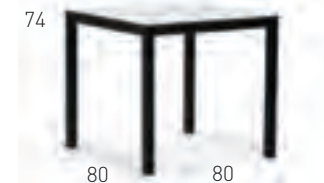

victor
cod. 3865
bianco lucido / grigio opaco / moka goffrato
glossy white / mat grey / mat dark brown
top alluminio forato bianco / moka
white / moka perforated top
top hpl bianco / quarzo goffrato
hpl top white / quartz micaceous



arena
cod. 1620
moka / dark brown
bianco / white



victor
cod. 3866
bianco lucido / grigio opaco / moka goffrato
glossy white / mat grey / mat dark brown
top hpl bianco / quarzo goffrato
hpl top white / quartz micaceous



victor
cod. 3867
bianco lucido / grigio opaco / moka goffrato
glossy white / mat grey / mat dark brown
top hpl bianco / quarzo goffrato
hpl top white / quartz micaceous



victor
cod. 2845
silver e teak
silver and teak

TAVOLI / TABLES



victor
cod. 3900
bianco lucido / grigio opaco / moka goffrato
glossy white / mat grey / mat dark brown
top hpl bianco / quarzo goffrato
hpl top white / quartz micaceous

PANCA / BENCHES



lotus
cod. 3970
naturale / moka
natural / dark brown

LETTINI / SUNBEDS



altea
cod. 2849
bronzo / moka / bianco
bronze / dark brown / white



loop
cod. 2865
bianco / nero
white / black
inox 304EP
stainless steel 304EP



lotus
cod. 2852
bianco / moka / corda / naturale
white / dark brown / silk grey / natural



marine
cod. 2881
bianco / nero
white / black
AISI 316L
stainless steel AISI 316L



pisolo
cod. 2860
bianco / moka
white / dark brown



pisolo
cod. 2861
bianco / moka
white / dark brown



victor
cod. 2822T
struttura moka gofrato
bianco lucido / grigio opaco
strutture dark brown micaceous
glossy white / mat grey
batyline moka / bianco / grigio / nero / turchese
batyline dark brown / white / grey / black / cyan



victor
cod. 2822TC
struttura moka gofrato / bianco lucido / grigio opaco
strutture glossy white / dark brown
micaceous / mat grey
batyline moka / bianco / grigio
batyline dark brown / white / grey



victor
cod. 2823T
struttura bianco lucido
strutture glossy white
batyline bianco
batyline white



victor
cod. 2912
struttura bianco lucido
strutture glossy white
intreccio bianco
white weaving



victor
cod. 2912T
bianco lucido / grigio opaco
glossy white / mat grey
batyline nero / grigio / turchese
batyline black / grey / cyan

POUFF / POUFF



arena
cod. 1619
bianco / bronzo / moka
white / bronze / dark brown



avalon
cod. 1066P
moka / dark brown
inox 304EP
stainless steel 304EP



cora
cod. 3083P
bianco / moka / corda
white / dark brown / silk grey



cora
cod. 3084P
bianco / moka / corda
white / dark brown / silk grey



domino
cod. 1052
bianco / moka
white / dark brown



giada
cod. 1055
bianco / moka
white / dark brown



loop
cod. 1058
bianco / nero
white / black
inox 304 EP
stainless steel 304 EP

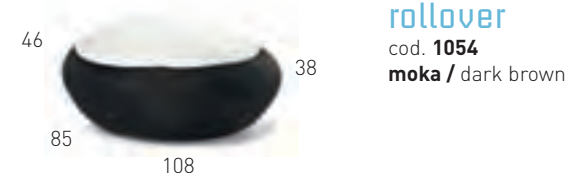

rollover
cod. 1054
moka / dark brown

FLORIERE / FLOWER BOXES



giada
cod. 4706
bianco / moka
white / dark brown



giada
cod. 4707
bianco / moka
white / dark brown



loop
cod. 4708
bianco / nero
white / black



loop
cod. 4714
bianco / nero
white / black



loop
cod. 4715
bianco / nero
white / black



loop
cod. 4716
bianco / nero
white / black

BASI / TABLE BASES



big
cod. 13600 / 13601 / 13602 / 13603
bianco / moka / grigio / ciano
white / moka / grey / cyan



big
cod. 1361
bianco / moka / grigio / ciano
white / moka / grey / cyan



lotus
cod. 37710 / 37711 / 37712 /
37713 / 37714
bianco / bronzo / corda /
moka / naturale
white / bronze / silk grey /
dark brown / natural



lotus
cod. 37730 / 37731 / 37732 /
37733 / 37734
bianco / corda / moka
white / silk grey / dark brown



lotus
cod. 37790
bianco / bronzo / corda /
moka / naturale
white / bronze / silk grey /
dark brown / natural



metrò
cod. 37530
anodizzato argento
silver anodized



metrò
cod. 37510 / 37511 / 37512 /
37513 / 37514
argento anodizzato
silver anodized



metrò
cod. 37520 / 37521 / 37522 /
37523 / 37524
anodizzato argento
silver anodized

BASI / TABLE BASES

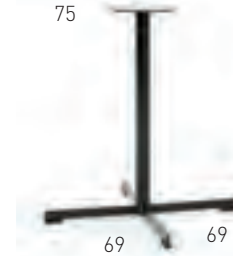

summer set
cod. 3133 / 3134 / 3119 /
3129 / 3139 / 3149
bianco / moka / grigio / ciano
white / moka / grey / cyan

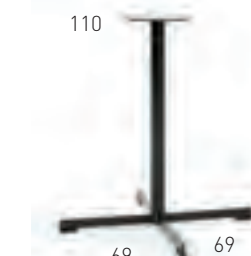

summer set
cod. 3128 / 3127
bianco / moka / grigio / ciano
white / moka / grey / cyan



tuxedo
cod. 37800 / 37801 / 37802 /
37803 / 37804
bianco / moka / grigio / ciano
white / moka / grey / cyan



victor
cod. 37760 / 37761 / 37762 /
37763 / 37764
bianco / grigio / moka /
argento anodizzato
white / grey / moka / silver
anodized

ACCESSORI / ACCESSORIES

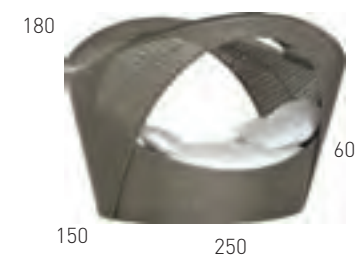

altea
cod. 1626
bronzio / moka / bianco
bronze / dark brown / white



altea
cod. 2892 / 2992
bianco / bronzio / moka
white / bronze / dark brown



altea
cod. 3400
bianco / white
moka / dark brown

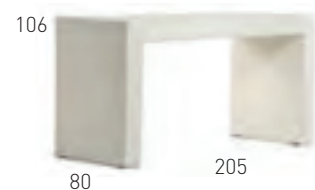

cora
cod. 3839
bianco / moka
white / dark brown



lotus
cod. 4740
struttura in ferro colore moka
moka metal structure



lotus
cod. 4754
struttura in alluminio
e acciaio inox 304 EP
aluminium and stainless
steel 304 EP structure



pavilion
cod. 1970
gazebo pavilion bianco
completo di pavimento,
coperture, 2 pannelli privacy
e tende laterali
white pavilion complete with
floor, coverings, 2 privacy
panels and side curtains



tulip
cod. 2876
bianco / white
bronzio / bronze
moka / dark brown

VARASCHIN

credits

AD_ Daniele Lo Scalzo Moscheri

STYLING_ Cora Vohwinkel _ Irene Baratto / Studioverderame

PHOTO_ Matteo Imbriani _ Sara Gerometta

FOTOLITO_ lucegroup.it

STAMPA_ www.sincromia.it cod. 133105

Thanks

Alessi

Antonio Aricò

Axolight

Belnotes

Collistar

Littala

Newmax

Paola C.

Society

Sonia Pedrazzini

Stampa gennaio 2014

Varaschin S.p.A
via Cervano 20 / 31029
Vittorio Veneto
Italia

T_ 39 0438 56 45
F_ 39 0438 564 666

varaschin@varaschin.it
www.varaschin.it