

News 2013 - 2014

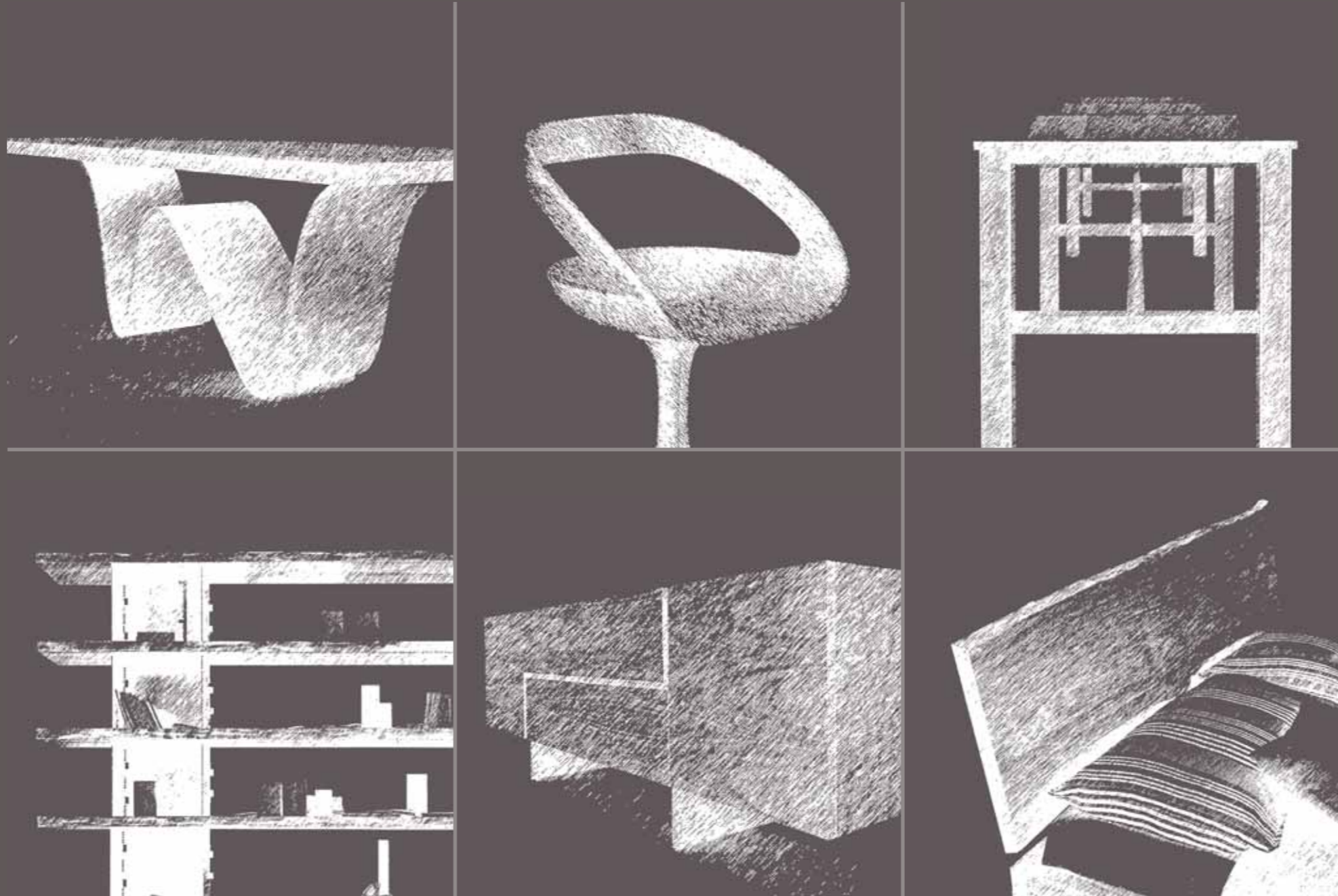

## Museo del legno Showroom

Museum of wood  
Showroom

Holzmuseum  
Ausstellung

**Museo del Legno e Showroom, nella nuova sede di via Milano 110 a Cantù - Italia.**

La struttura è quasi interamente ricoperta in legno di larice, tra i più resistenti alle intemperie meteorologiche e allo scorrere del tempo. Al primo piano, si trova il Museo del Legno, dove vengono proposti oltre 2000 macchine e utensili storici per la lavorazione del legno. Una collezione unica nel suo genere in Italia, per la quantità di pezzi esposti. Al piano terra, invece, si trova il nuovo Showroom Riva1920, un ambiente ampio circa 1200 mq, che esalta tutte le finiture esposte e destinato ad accogliere le creazioni più attuali, i progetti che verranno nel prossimo futuro e i clienti che vorranno toccare con mano la qualità Riva. **Entrata libera.**

**Museum of Wood and Showroom at Riva 1920's new centre in Via Milano 110, Cantù, Italy.**

The structure of the new centre is almost entirely covered with larch-wood, one of the most long lasting and weather-resistant woods. The top floor houses the Museum of Wood, which gathers over 2000 historic woodworking machines and tools. This is the biggest of such collections in the whole of Italy. The ground floor of the building hosts the new Showroom, aimed at gathering the company's latest creations, the projects proposed for realization in the near future and aimed at welcoming clients who are there able to see and touch the renowned Riva 1920's quality. This space, as large as ca 1200 square metres, is the perfect niche to enhance the finishing touches of Riva 1920's products. The area also gathers special projects that have been milestones in the company's history. **Free entrance.**

**Neue Räume für Holzmuseum und Showroom in Via Milano 110 in Cantù, Italien.**

Die Struktur ist fast komplett mit Lärche verkleidet, welches eines der resistenteren Hölzern ist, unter Wirkung von Meteorologischen Ereignissen und in der Zeit. Im oberen Stockwerk befindet sich das Holzmuseum, in dem über 2.000 historische Maschinen und Handwerkzeuge zur Bearbeitung von Holz ausgestellt sind. Eine Kollektion Einzigartig dieser Art in Italien für die Anzahl der Exponate. Im Erdgeschoss finden Sie auf über 1200 m<sup>2</sup> neuer Ausstellungsfläche die Neuheiten unserer Kollektion, es eröffnen sich Räume welche die aktuellen Kreationen vorstellen und in denen die zukünftigen Projekte präsentiert werden. Hier haben die Kunden die RIVA Qualität zum anfassen. **Freier Eintritt.**

Info at: [riva1920@riva1920.it](mailto:riva1920@riva1920.it)



*IL LEGNO E LA TRADIZIONE*  
**WOOD AND TRADITION**  
*HOLZ UND TRADITION*

- 03 **Tavoli**  
Tables - Tische
- 42 **Tavolini**  
Small tables - Couchtische
- 48 **Sedie/Sgabelli/Poltrone/Divani**  
Chairs/Stools/Armchairs/Sofas - Stühle/Hocker/Sessel/Sofas
- 82 **Panche**  
Benches - Bänke
- 91 **Mobili/Vetrine**  
Chest of drawers/Cabinets - Kommoden/Vitrine
- 118 **Librerie**  
Bookshelves - Regalsysteme
- 140 **Letti/Comodini/Armadi**  
Beds/Night tables/Wardrobes - Betten/Nachttische/Schränke
- 155 **Campionario**  
Sample charts - Muster



**PRODURRE  
CON ONESTÀ  
PER TRAMANDARE**

Ogni giorno mi sento di lottare per migliorare il mondo in cui viviamo poiché a tuttora non vi è un altro pianeta per ricollocarci.

*Maurizio Riva*

**DESIGNED WITH INTEGRITY  
TO BE ENJOYED FOR  
GENERATIONS TO COME**

Every day I feel like fighting for a better world, because there still is no other planet where we can relocate.

*Maurizio Riva*

**EHRLICHE HANDARBEIT  
LÄSST DIE TRADITION  
WEITERLEBEN**

Jeden Tag fühle ich die Notwendigkeit, für eine bessere Welt zu kämpfen, weil es keinen anderen Planeten gibt, auf den wir hinziehen können.

*Maurizio Riva*



# Tavoli Tables Tische

- |    |   |    |  |
|----|---|----|--|
| 04 | <b>BREE E ONDA</b><br>DESIGN: PASSON E SAVORGNANI             | 26 | <b>NERIO</b><br>DESIGN: NATURA COLLECTION BY RIVA                  |
| 06 | <b>AUCKLAND BREE E ONDA</b><br>DESIGN: PASSON E SAVORGNANI    | 28 | <b>TUBULAR</b><br>DESIGN: JAMIE DURIE                              |
| 08 | <b>SW TABLE</b><br>DESIGN: JOHN FORD                          | 30 | <b>LEX NATURAL SIDES</b><br>DESIGN: NATURA COLLECTION BY RIVA      |
| 10 | <b>LIAM</b><br>DESIGN: NATURA COLLECTION BY RIVA              | 32 | <b>PARLA_SMALL - PARLA_BIG</b><br>DESIGN: KARSTEN SCHMIDT-HOENSORF |
| 12 | <b>SKY NATURAL SIDES</b><br>DESIGN: NATURA COLLECTION BY RIVA | 34 | <b>PINOMUGO</b><br>DESIGN: RICCARDO ARBIZZONI                      |
| 14 | <b>SKY SQUARED</b><br>DESIGN: NATURA COLLECTION BY RIVA       | 35 | <b>NAVARRA</b><br>DESIGN: CR&S RIVA 1920                           |
| 15 | <b>SKY BRICCOLA</b><br>DESIGN: NATURA COLLECTION BY RIVA      | 36 | <b>FRAME</b><br>DESIGN: CR&S RIVA 1920                             |
| 16 | <b>WOODSTOCK</b><br>DESIGN: NATURA COLLECTION BY RIVA         | 38 | <b>ARABESQUE</b><br>DESIGN: LUCA SCACCHETTI                        |
| 20 | <b>TRAVERSO</b><br>DESIGN: GIOVANNA AZZARELLO                 | 39 | <b>SHERWOOD 2013</b><br>DESIGN: CR&S RIVA 1920                     |
| 22 | <b>SLEEK</b><br>DESIGN: KARIM RASHID                          | 40 | <b>COLINO ROUND</b><br>DESIGN: MICHELE DE LUCCHI                   |
| 24 | <b>TOUCH</b><br>DESIGN: CARLO COLOMBO                         | 41 | <b>PEO</b><br>DESIGN: CR&S RIVA 1920                               |
| 25 | <b>HUG</b><br>DESIGN: ALESSANDRO BONATO                       |    |  |



## BREE E ONDA

Design: Passon e Savorgnani

La passione per un materiale sincero ed il legame con le proprie radici. La sfida delle nuove tecnologie, dei nuovi materiali e del loro rapporto con la tradizione. Questa dicotomia è alla base del design del tavolo Bree e Onda. Tavolo con top in legno massello spessore 5 cm. Base realizzata in tubolare di metallo (standard laccata "irondust") spessore 2,5 cm., resistente alle sollecitazioni, lavorata con una particolare forma sinuosa che ricorda le onde del mare. A richiesta base disponibile in altri colori della scala RAL.

Passion for authentic material and connection with one's roots. The challenge of new technologies, new materials and their relation to tradition. This dichotomy underpins the concept of the table Bree e Onda. Table with top in 5 cm-thick solid wood. Base made of tubular frame (standard lacquered "irondust" colour) thickness 2.5 cm, strong and resistant to stress, with a sinuous shape recalling the waves of the sea. Base available in other RAL colours on demand.

Leidenschaft für ein unverfälschtes Material in Verbindung mit dem Rückkehr zu den eigenen Wurzeln. Die Herausforderung der neuen Technologien, der neuen Materialien und die Verbindung mit der Tradition. Diese zwei Elemente sind die Grundlagen für das Design des Tisches Bree e Onda. Tisch mit 5 cm dicken Tischplatte. Das Gestell ist aus 2,5 cm dickem Metallrohr (Standard-Farbe "irondust"), widerstandsfähig und belastbar, hergestellt mit geschwungenen Formen, die an Wellen des Meeres erinnern. Auf Anfrage ist das Gestell auch in den anderen Farben der Farb-Palette RAL erhältlich.

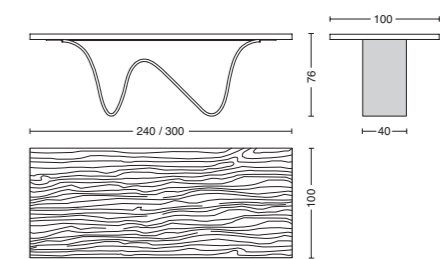

Cod. BREE E ONDA

H. 76 cm. (standard)  
L. 240 - P. 100  
L. 260 - P. 100  
L. 280 - P. 100  
L. 300 - P. 100



## AUCKLAND BREE E ONDA

Design: Passon e Savorgnani

Il tavolo Bree e Onda assume una nuova connotazione grazie all'introduzione del Kauri, legno millenario, utilizzato per il piano. Il sostegno è garantito da un' "Onda" di ferro naturale rivestita di resina oppure laccata nei vari colori. I due elementi naturali, legno e ferro, si fondono insieme in un movimento armonico.

The Bree e Onda table acquires a new interpretation thanks to the use of thousand-year old Kauri wood for the table top. The support is guaranteed through a natural iron "Wave" covered in resin or lacquered in different colours. The two natural elements, wood and iron, merge to create a single harmonious movement.

Der Tisch Bree e Onda gewinnt eine neue Bedeutung dank der Verwendung des Jahrtausend alten Kauri-Holzes für die neue Tischplatte. Eine "Welle" aus Natur-Eisen, verkleidet mit Kunstharz oder in verschiedenen Farben lackiert, garantiert die Stütze der Platte. Die zwei natürlichen Elemente, Holz und Eisen, vereinen sich zu einer harmonischen Bewegung.

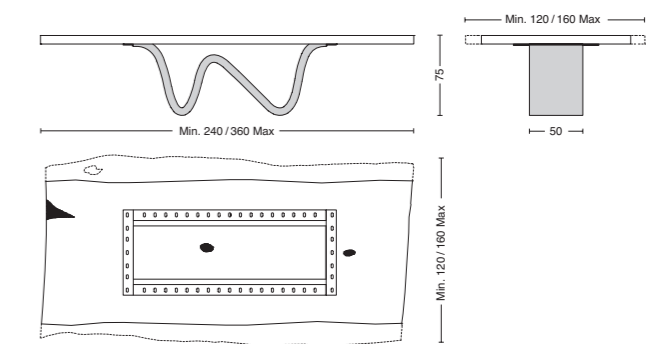

Cod. KAURI BREE E ONDA



## SW TABLE

Design: John Ford

Tra i concorsi di idee che Riva 1920 ha promosso nell'anno 2013, uno dei progetti vincitori è risultato essere quello del designer Americano John Ford con il suo tavolo "SW Table". Tavolo completamente in legno massello. Il top con bordi esterni rastremati e il particolare effetto delle gambe oblique e sfaccettate donano al tavolo un effetto di grande leggerezza. Disponibile su misura e nelle diverse essenze previste dalla Collezione.

One of the winning designs in the competition sponsored by Riva 1920 in 2013 was one by the American designer John Ford with his "SW Table". The table is made completely of solid wood. The top with its combed sides and the highly individual effect of the oblique, angled legs combine to give the product the appearance of great lightness. Available as a made-to-measure item in any of the Collection's wood materials.

Unter den von Riva 1920 im Jahr 2013 durchgeführten Ideen – Wettbewerben erwies sich als einer der Gewinner – Projekte das des amerikanischen Designers John Ford mit seinem Tisch "SW Table". Tisch vollständig aus Massivholz. Die Tischplatte mit sich verjüngenden Außenkanten und dem besonderen Effekt der geneigten und facettenreichen Tischbeine verleihen dem Tisch einen Anschein von Leichtigkeit. Erhältlich nach Maß und in den von der Kollektion vorgesehenen Holzarten.

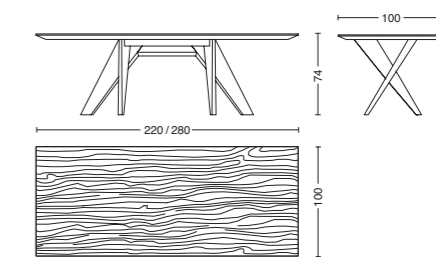

Cod. SW

H. 74 cm. (standard)  
L. 220 – P. 100  
L. 240 – P. 100  
L. 260 – P. 100  
L. 280 – P. 100



## LIAM

Design: Natura Collection by Riva

Tavolo dal design particolare caratterizzato dalla gamba asimmetrica. Modello versatile sia per l'arredo casa che per l'ufficio o comunità. Realizzato totalmente in legno massello, disponibile nelle essenze a catalogo con piastra di sostegno laccato grigio antracite "Iron dust" (standard) o su richiesta laccata trasparente o in altri colori della scala RAL.

Table with an unusual design thanks to the asymmetric leg; suitable both for home and office use. Made completely of solid wood, available in the different woods of our range, with floor support lacquered in "Iron dust" (anthracite grey), or, upon request, transparent coating or in other RAL colours.

Mit seinem durch das asymmetrische Tischbein charakterisierten Tisch - Design ist das Modell sowohl für den Home Bereich als auch für den Office Bereich geeignet. Vollständig aus Massivholz. Der Tisch ist in den von dem Katalog vorgesehenen Holzarten mit Bodenplatte lackiert Anthrazit grau "Iron dust" (Standard) oder auf Anfrage transparent lackiert oder in anderen Farben der Farbskala RAL erhältlich.

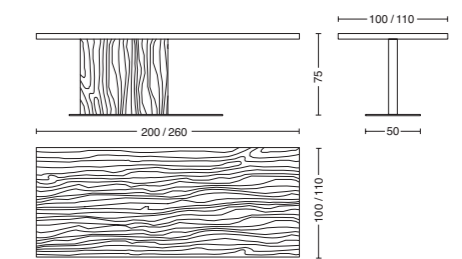

### Cod. 3.68

H. 75 cm. (standard)  
 L. 200 - P. 100  
 L. 220 - P. 100  
 L. 240 - P. 100  
 L. 260 - P. 100  
 L. 200 - P. 110  
 L. 220 - P. 110  
 L. 240 - P. 110  
 L. 260 - P. 110





## SKY NATURAL SIDES

Design: Natura Collection by Riva

Tavolo in legno massello, costituito da liste incollate, con lati naturali, spessore di 4 cm. Disponibile in rovere e in noce americano con nodi. Gambe in ferro, laccate color trasparente opaco, dalla caratteristica forma a rombo.

Table featuring a 4 cm-thick solid wood top, with natural sides, available in American oak or walnut with knots. Legs in iron, lacquered mat transparent, with distinctive flattened diamond shape.

Tischplatte aus 4 cm starkem Massivholz, verleimten Stäben, mit Naturkanten. Erhältlich in Eiche oder amerikanischem Nussbaum, mit Knoten. Gestell aus matt transparent lackiertem Eisen, in charakteristischer Rauten Form.

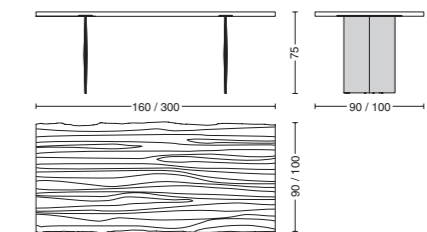

### Cod. NAT-SKY

H. 75 cm. (standard)  
 L. 160 - P. 90  
 L. 180 - P. 90  
 L. 200 - P. 90  
 L. 220 - P. 100  
 L. 240 - P. 100  
 L. 260 - P. 100  
 L. 280 - P. 100  
 L. 300 - P. 100

## SKY SQUARED

Design: Natura Collection by Riva

Tavolo con top interamente in legno massello, spessore di 4 cm, costituito da liste incollate, con lati squadrati. Disponibile in rovere e in noce americano, con nodi. Gambe in ferro, laccate color trasparente opaco, dalla caratteristica forma a rombo.

Square side table featuring a 4 cm-thick solid wood top, made up of glued strips, available in American oak or walnut, with knots. Legs in iron, lacquered mat transparent, with distinctive flattened diamond shape.

Tischplatte aus 4 cm starkem Massivholz, verleimten Stäben, mit geraden Kanten. Erhältlich in Eiche oder a amerikanischem Nussbaum, mit Knoten. Gestell aus matt transparent lackiertem Eisen, in charakteristischen Rauten Form.

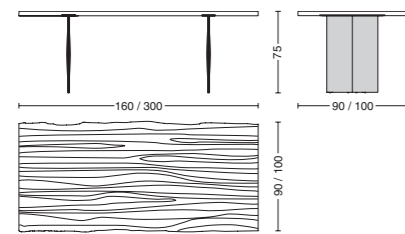

### Cod. NAT-SKY

H. 75 cm. (standard)  
 L. 160 - P. 90  
 L. 180 - P. 90  
 L. 200 - P. 90  
 L. 220 - P. 100  
 L. 240 - P. 100  
 L. 260 - P. 100  
 L. 280 - P. 100  
 L. 300 - P. 100



## SKY BRICCOLA

Design: Natura Collection by Riva

Tavolo con top interamente in legno massello di rovere "Briccola" (legno di risulta dei pali della laguna di Venezia), costituito da liste accostate, con lati naturali, spessore di 4 cm., finitura a cera. Gambe in ferro, laccate color trasparente opaco, dalla caratteristica forma a rombo.

Table in solid "Briccola" oak wood (recycled marker-posts recovered from the Venice Lagoon) featuring a 4 cm-thick top, made up of planks laid flush with natural sides. Iron legs with distinctive flattened diamond shape finished with mat transparent lacquer.

Tischplatte aus 4 cm starkem Massivholz "Briccole" (Pfähle aus der venezianischen Lagune), nebeneinander Stäbe mit Fugen und Naturkanten. Gestell aus matt transparent lackiertem Eisen, in charakteristischer Rauten Form.

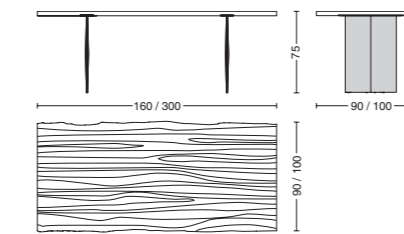

### Cod. NAT-SKY BRICCOLA

H. 75 cm. (standard)  
 L. 160 - P. 90  
 L. 180 - P. 90  
 L. 200 - P. 90  
 L. 220 - P. 100  
 L. 240 - P. 100  
 L. 260 - P. 100  
 L. 280 - P. 100  
 L. 300 - P. 100



## WOODSTOCK

Design: Natura Collection by Riva

Il tavolo WOODSTOCK è realizzato con un piano in legno massello di noce americano dello spessore di circa 9 cm. composto a sua volta da tavole in legno di varie dimensioni incollate tra loro in larghezza. Questi piani con spessori straordinari necessitano una preparazione e un'essiccazione del materiale legno molto più lunghi rispetto al normale processo di essiccazione adottato per un piano dello spessore medio di 4 o 5 cm. Pertanto i tempi di consegna di questo prodotto sono piuttosto lunghi, dai 4 ai 6 mesi a seconda della disponibilità del materiale. Vi consigliamo di contattare l'Ufficio Commerciale RIVA per conoscere il tempo di consegna stimato. E' bene ricordare che il legno è un materiale "vivo", che per tutta la vita del mobile continuerà a interagire con l'ambiente circostante e restando sensibile al calore e specialmente al grado di umidità dell'aria. Un grado di umidità troppo basso (come per esempio un ambiente riscaldato con ventilatori ad aria calda o termosifoni a parete o serpentina a pavimento senza adeguata umidificazione) potrebbe portare a fessure nel legno. Si consiglia inoltre di non posizionare il tavolo troppo vicino da fonti dirette di calore come stufe, caminetti. Mantenere nell'ambiente un'umidità ideale intorno al 50% - 55%. Nel caso che si presentino fessurazioni del legno (dovute alle modificazioni delle condizioni ambientali sopra menzionate), se sono di piccole dimensioni si possono chiudere con un apposito "stucco a cera", facile da trovare in commercio (oppure reperibile presso i Rivenditori autorizzati RIVA 1920) in formato di stick di varie colorazioni. Si consiglia di usare l'ecostucco monocomponente ad acqua. Si procede in questo modo: dopo aver scaldato lo stucco per renderlo più morbido, lo si fa penetrare con cura sfregando energicamente la parte stuccata con un panno in modo far penetrare la quantità di stucco / cera nella fessura e infine rimuovere lo stucco / cera in eccesso ed eventuali sbavature. Una volta asciutto, lo stucco a cera deve essere ben levigato con della carta vetrata a grana sottile e oliare nuovamente la parte del tavolo trattata. Non usare mai prodotti chimici o sostanze abrasive o set di manutenzioni diversi dal set RIVA 1920.

The WOODSTOCK table has a 9-cm-thick tabletop in solid American walnut composed of wooden boards of different dimensions laced face to face and glued together. Because of their extraordinary thickness, these tops need a selection and drying process that is much longer than usually adopted for a top whose average thickness is 4 or 5 cm. The delivery-time of this item is therefore quite long – about 4-6 months depending on the availability of the material. We suggest you to contact RIVA Export Department to know the expected delivery-time. We remind you that wood is a "living" material, which will interact with the surrounding environment for the whole life of the furniture and be subject to heat and, above all, to different degrees of humidity. Too low a level of humidity (for example, in a room heated by warm air blowing fans, wall heating systems or floor-level heating coils, without proper humidification) can produce splits in the wood. Besides, we recommend not putting the table too near to direct heat sources like stoves or fireplaces and to maintain an ideal humidity level of between 50% and 55%. If small splits appear in the wood (caused by changes in the environmental conditions, as explained above), they can be repaired using a special but commercially easily available "soft wax" (ask your RIVA 1920 dealer) which comes in the form of different coloured sticks. We suggest you use some eco-friendly, single-component water-based filler. You can proceed as follows: after having heated the stick to make it softer, vigorously rub down the piece with great care using a cloth till the split is filled with the wax and then remove any excess or smears. When it is dry, the wax needs to be well rubbed down with thin sandpaper or stainless steel wool. Then treat the wooden top again with our natural oil. Never use chemical products or abrasive substances or maintenance kits different from the one supplied by RIVA 1920.

Der Tisch WOODSTOCK wird mit einer Massivholzplatte Stärke 9 cm aus Amerikanischen Nussbaum gefertigt!!! Tischplatten mit dieser außergewöhnlichen Materialstärke, nehmen eine wesentliche längere Bearbeitung und Trocknungszeit in Anspruch, wie die herkömmlichen Plattenstärken mit bis zu 5 cm. Des weiteren ist die Verfügbarkeit solch massiver Planken nicht mit der eigentlichen Holzbeschaffung zu vergleichen. Auf Grund dieser Beschaffungsmerkmale müssen wir Sie bitten eine Lieferzeit von 4 – 6 Monaten zu kalkulieren. Es wird darauf hingewiesen, dass Holz ein "lebendes" Material ist, das auf Umwelteinflüsse wie Wärme und Luftfeuchtigkeit sehr sensibel reagiert. Eine zu geringe Luftfeuchtigkeit (wie z.B. mit Heißluft oder Warmwasserheizanlagen oder Fußbodenheizung beheizte Ambiente ohne angemessene Luftbefeuchtung) könnte kleine Risse im Holz verursachen. Es wird auch geraten den Tisch nicht zu nahe an direkte Wärmequellen wie Heizkörper oder Kamine zu stellen. Die ideale Luftfeuchtigkeit sollte zwischen 50% und 55% liegen. Im Fall von kleinen Rissen im Holz (verursacht durch die oben angeführten Änderungen der Raumbedingungen) können Sie diese mit einem speziellen Wachs/Kitt in verschiedene Farben und in Stick Form, erhältlich im Handel oder bei autorisierten Einzelhändlern RIVA1920 schließen. Es wird geraten einen Eco Kitt auf Wasserbasis zu verwenden. Verwendungsanweisung: das Wachs wird erwärmt, um es weicher zu machen, dann aufgetragen und mit einem weichen Tuch energisch eingerieben. Auf diese Weisedringt das Wachs/Kitt in die Risse ein und überflüssiges Wachs/Kitt wird entfernt. Nach dem Trocknen muss das Wachs/Kitt mit Glaspapier abgeschliffen und dieser Tischteil gut eingeeölt werden. Chemische Produkte oder abschleifende Substanzen dürfen auf keinen Fall verwendet werden. Die perfekte Pflege wird nur durch das Pflegeset RIVA 1920 garantiert.

Tavolo con top interamente in legno massello in noce americano, nella caratteristica qualità con nodi. Nella versione standard: gambe in ferro color naturale dalla caratteristica forma a piramide. Disponibile anche con base tavolo mod. "Sherwood", "Newton" e "Calle", sia in ferro naturale sia in altre finiture laccate.

Table featuring a 9-cm-thick solid wood top with natural sides, available in American walnut, with characteristic knotty graining. Standard version: legs in iron, natural colour, with unusual pyramidal shape. Also available with base of "Sherwood", "Newton" or "Calle" models, in natural iron colour or other lacquered finishes.

Tischplatte aus 9 cm starkem Massivholz mit Naturkanten. Erhältlich in amerikanischem Nussbaum mit Knoten. Standard: mit Gestell aus Roheisen, pyramidenförmig. Auch mit dem Gestell mod. "Sherwood", "Newton" oder "Calle" erhältlich.



## WOODSTOCK

Design: Natura Collection by Riva

Cod. WOODSTOCK

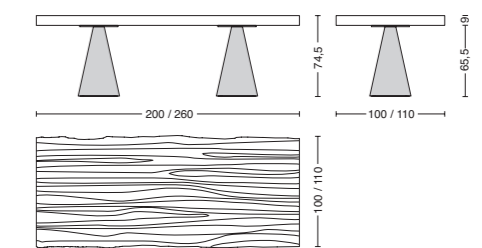

H. 74,5 cm. (standard)  
L. 200 - P. 100  
L. 220 - P. 100  
L. 240 - P. 100  
L. 260 - P. 100  
L. 200 - P. 110  
L. 220 - P. 110  
L. 240 - P. 110  
L. 260 - P. 110

## WOODSTOCK-CALLECULT

Design: Natura Collection by Riva

Cod. WOODSTOCK\_CALLECULT

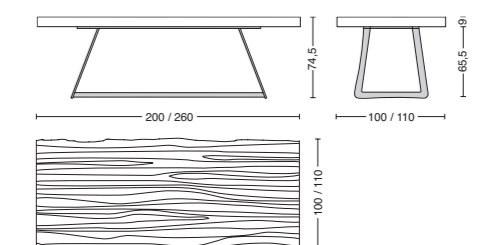

H. 74,5 cm. (standard)  
L. 200 - P. 100  
L. 220 - P. 100  
L. 240 - P. 100  
L. 260 - P. 100  
L. 200 - P. 110  
L. 220 - P. 110  
L. 240 - P. 110  
L. 260 - P. 110



## WOODSTOCK-NEWTON

Design: Natura Collection by Riva



Cod. WOODSTOCK\_NEWTON

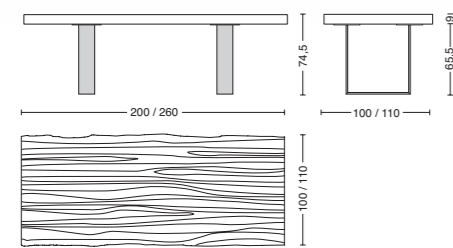

H. 74,5 cm. (standard)  
L. 200 - P. 100  
L. 220 - P. 100  
L. 240 - P. 100  
L. 260 - P. 100  
L. 200 - P. 110  
L. 220 - P. 110  
L. 240 - P. 110  
L. 260 - P. 110



## WOODSTOCK-SHERWOOD

Design: Natura Collection by Riva



Cod. WOODSTOCK\_SHERWOOD

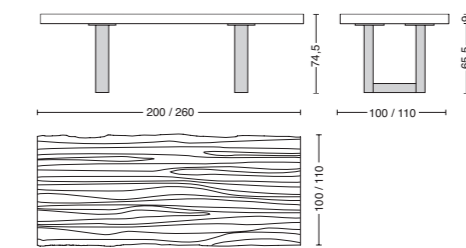

H. 74,5 cm. (standard)  
L. 200 - P. 100  
L. 220 - P. 100  
L. 240 - P. 100  
L. 260 - P. 100  
L. 200 - P. 110  
L. 220 - P. 110  
L. 240 - P. 110  
L. 260 - P. 110





## TRAVERSO

Design: Giovanna Azzarello

Tavolo completamente realizzato in legno massello disponibile nelle essenze ciliegio, acero, rovere e noce senza nodi. Spessore top 4 cm. Base con particolare incrocio delle traverse che danno movimento al tavolo.

Made completely of solid wood and available in cherry, maple, oak and walnut, without knots. Table top thickness 4 cm. The base has a special system of intersecting crossbeams, which give the table a flowing movement.

Tisch, ganz aus Massivholz, in Kirsch, Ahorn, Eiche und Nussbaum ohne Knoten erhältlich. Tischplatte 4 cm dick. Das Gestell aus gekreuzten Stäben verleiht dem Tisch den Anschein von Bewegung.

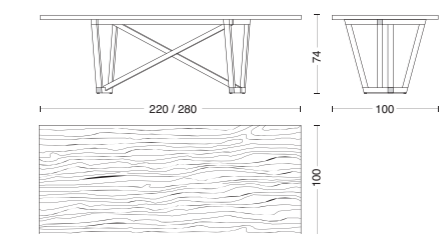
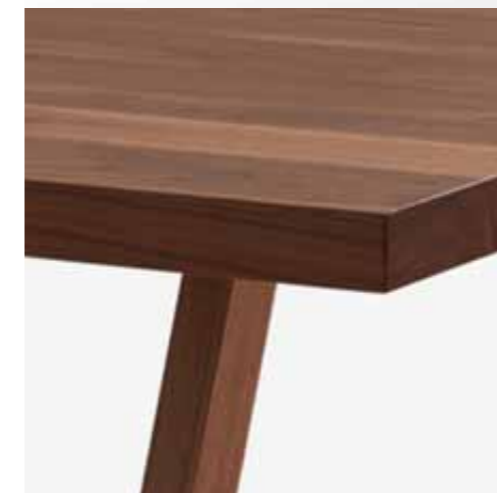

Cod. TRAVERSO

H. 74 cm. (standard)  
L. 220 - P. 100  
L. 240 - P. 100  
L. 260 - P. 100  
L. 280 - P. 100



## SLEEK

Design: Karim Rashid

Tavolo dal design sinuoso ed elegante. Le gambe in legno massello, rinforzate da una struttura in metallo interna, si uniscono al top mediante il particolare sistema a coda di rondine. Disponibile in tutte le essenze previste.

A table with an elegant, sinuous design. The legs are in solid wood, reinforced with an internal metal structure and joined to the top by means of a special system of dove-tail joints. Available in all the range's wood types.

Tisch mit einem geschwungenen und eleganten Design. Die Tischbeine sind aus Massivholz, verstärkt mit einer inneren Metallstruktur, und mit der Tischplatte durch ein besonderes Schwalbenschwanz System verbunden. Erhältlich in allen Holzarten.

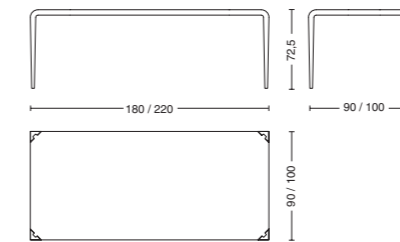

### Cod. SLEEK

H. 72,5 cm. (standard)  
L. 180 - P. 90  
L. 200 - P. 90  
L. 220 - P. 90  
L. 180 - P. 100  
L. 200 - P. 100  
L. 220 - P. 100



## TOUCH

Design: Carlo Colombo

Modello nato per la Collezione "Briccole di Venezia", è ora disponibile negli altri legni della Collezione Riva 1920.

Il top è realizzato da tavole spessore 5 cm. accostate trasversalmente. Per conferire movimento e naturalezza al tavolo i lati corti sono lasciati naturali con la forma naturale del legno.

A model originally for the "Briccole di Venezia" Collection and now available in other woods from the Riva 1920 Collection. The top is composed of 5 cm-thick boards, laid crosswise. To give the piece a sense of movement and naturalness, the short sides have been left natural exposing the natural form of the wood.

Das Modell der Kollektion "Briccole di Venezia" ist nun auch in den anderen Holzarten der Kollektion Riva 1920 erhältlich. Die Tischplatte besteht aus 5 cm starken, quer nebeneinander liegenden Leisten. Die kurzen Tischseiten wurden in ihrer natürlichen Form belassen, um dem Tisch Bewegung und Natürlichkeit zu verleihen.

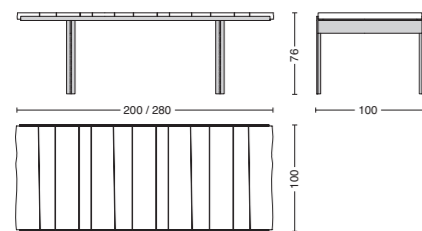

### Cod. TOUCH

H. 76 cm. (standard)  
L. 200 - P. 100  
L. 220 - P. 100  
L. 240 - P. 100  
L. 260 - P. 100  
L. 280 - P. 100



## HUG

Design: Alessandro Bonato

Tavolo dalle linee essenziali costituito da una struttura in metallo laccato che racchiude il top legno listellare spessore 3 cm., rivestito con impiallacciatura spessore 2 mm. Modello disponibile nelle misure indicate e in tutte le essenze previste dalla Collezione R1920.

A table with simple lines made up of a lacquered metal framework enclosing a 3 cm-thick top composed of blockboard with a 2 mm-thick veneer. The model comes in the dimensions shown and in all the types of wood available in the R1920 Collection.

Tisch mit essentiellen Linien. Die lackierte Metallstruktur umschließt die 3 cm dicke Tischplatte, die mit einer 2 mm dickem Furnier verkleidet ist. Das Modell ist erhältlich in den angegebenen Größen und in allen von der Kollektion R1920 vorgesehenen Holzarten.

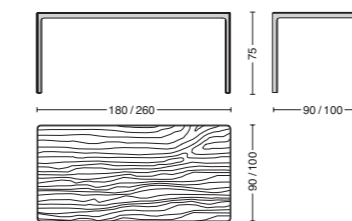

### Cod. HUG

H. 75 cm. (standard)  
L. 180 - P. 90  
L. 200 - P. 90  
L. 220 - P. 100  
L. 240 - P. 100  
L. 260 - P. 100





## NERIO

Design: Natura Collection by Riva

Tavolo con top e gambe interamente in legno massello, lati squadrati, spessore 9 cm, disponibile in noce americano, nella caratteristica qualità con nodi. Gambe e top assemblati tramite un sistema di viti passanti.

A table with both top and legs made entirely of solid wood; 9 cm-thick squared sides. Available in American walnut with its characteristic knots. Legs and top assembled using a system of long connecting screws.

Tisch mit Tischplatte und Tischbeinen aus Massivholz, mit rechteckigen Kanten, 9 cm dick, erhältlich aus amerikanischem Nussbaum mit Knoten. Tischbeine und Tischplatte sind durch ein System von Durchgangsverschraubung miteinander verbunden.

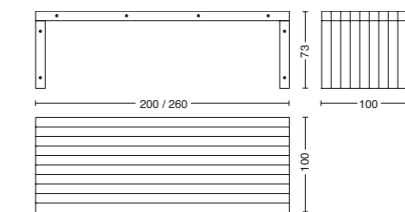

**Cod. NERIO**  
 H. 73 cm. (standard)  
 L. 200 - P. 100  
 L. 220 - P. 100  
 L. 240 - P. 100  
 L. 260 - P. 100





## TUBULAR

Design: Jamie Durie

Tavolo con top in legno massello disponibile in tutte le essenze: noce, rovere, ciliegio e acero. Lati esterni smussati ed arrotondati, che richiamano il tubolare in ferro della base.

Table with solid wood top, available in all woods of our range: walnut, oak, cherry and maple. All edges are smoothed and rounded to echo the tubular form of the iron base.

Tisch mit Tischplatte aus Massivholz, erhältlich in Nuss, Eiche, Kirsch und Ahorn. Die abgeschrägten und abgerundeten Außenkanten verweisen auf die Eisenrohrstruktur des Tisches.

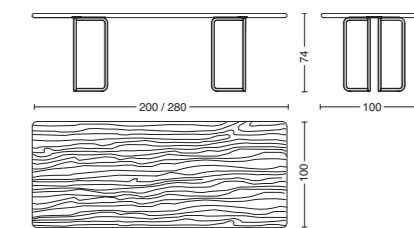

Cod. TUBULAR\_TAB

H. 74 cm. (standard)  
L. 200 - P. 100  
L. 220 - P. 100  
L. 240 - P. 100  
L. 260 - P. 100  
L. 280 - P. 100



## LEX NATURAL SIDES

Design: Natura Collection by Riva

Tavolo con top in massello con nodi in rovere o noce disponibile con lati naturali o squadri. Gambe in metallo laccato colore grigio antracite "irondust" (standard) o disponibile in altre colorazioni della scala RAL e in altre finiture come da Campionario della Collezione RIVA 1920.

Table with solid wood top with knots in either oak or walnut, available with natural or squared sides. Metal legs in anthracite grey "Irondust" (standard) or available in other RAL range colours and in other finishes on the RIVA 1920 Collection sample card.

Tisch mit Tischplatte aus Massivholz mit Knoten, aus Eiche oder Nussbaum, erhältlich mit Natur Kanten oder rechteckigen Kanten. Tischbeine aus Metall lackiert in Anthrazit grau "irondust" (Standard). Erhältlich auch in anderen Farben der Farbskala RAL und in anderen Ausführungen nach der Muster Kollektion RIVA 1920.

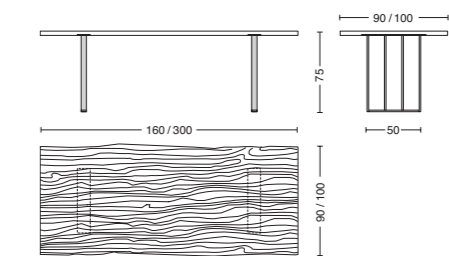

### Cod. NAT-LEX

H. 75 cm. (standard)  
 L. 160 - P. 90  
 L. 180 - P. 90  
 L. 200 - P. 90  
 L. 200 - P. 100  
 L. 240 - P. 100  
 L. 260 - P. 100  
 L. 280 - P. 100  
 L. 300 - P. 100



## PARLA\_SMALL - PARLA\_BIG

Design: Karsten Schmidt-Hoensdorf

Dalla collaborazione con il designer svizzero Karsten Schmidt e Riva1920 nasce la linea "Parla!": un elegante ed essenziale tavolo Bar, disponibile in due altezze e in tutte le essenze della collezione. Poggiapiiedi in metallo finitura bronzata. A richiesta è disponibile l'elemento portaborse posizionabile sotto il top.

The "Parla!" line is fruit of the collaboration between the Swiss designer Karsten Schmidt and Riva1920. It is an elegant table-Bar of great simplicity, available in two heights and two types of wood. The metal footrest is finished in bronze. A bag rack that can be placed under the top is also available on request.

Aus der Zusammenarbeit zwischen dem Schweizer Designer Karsten Schmidt und RIVA 1920 entsteht die Linie "Parla!": ein eleganter und essentieller Bartisch, erhältlich in zwei Höhen und in allen Holzarten der Kollektion. Fußstützen aus bronzefarbenem Metall. Auf Anfrage mit Taschenträger erhältlich.

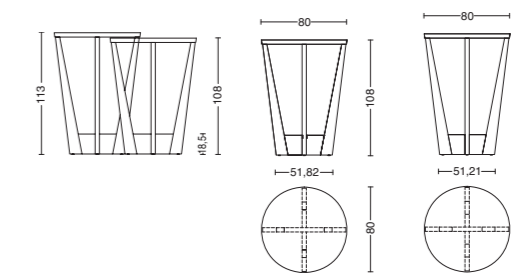
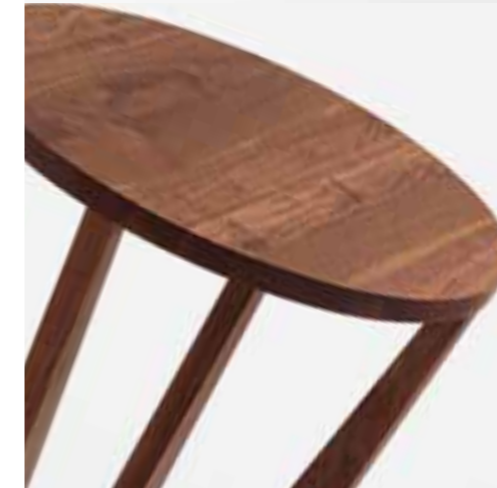

Cod. PARLA\_SMALL

Ø. 80 - H. 108

Cod. PARLA\_BIG

Ø. 80 - H. 113

## PINOMUGO

Design: Riccardo Arbizioni

Tavolo in massello. Top con caratteristica fresata a scalino sui due lati del tavolo. La gamba, realizzata in legno massello, richiama la forma stilizzata dell'albero da cui il disegno del tavolo trae ispirazione. Basamento in ferro naturale o, a richiesta, in vari colori della scala Ral.

Table in solid wood. Top has characteristic stepped groove on both sides of the table. The stylised form of the leg, made of solid wood, draws its inspiration from the tree whose name it takes. Base in natural iron or, if requested, in other RAL range colours.

Tisch aus Massivholz. Auf zwei Seiten ist die Tischplatte abgestuft gefräst. Die stilisierte Form der Tischbeine inspiriert sich an der Form des Baumes, von dem der Name des Tisches abgeleitet ist. Der Unterbau ist aus Natureisen, oder, auf Anfrage lackiert in den Farben der Farbskala Ral.

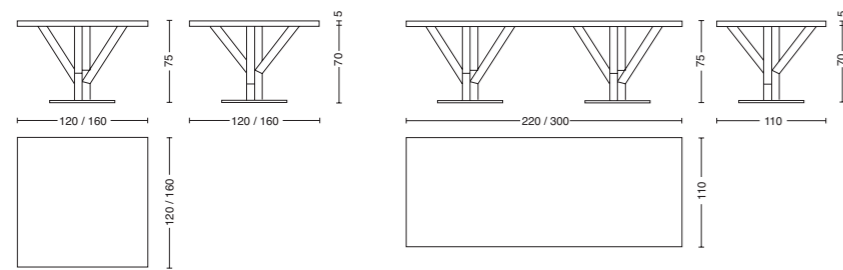

### Cod. PINOMUGO

H. 75 cm. (standard)  
L. 120 - P. 120  
L. 140 - P. 140  
L. 160 - P. 160

L. 220 - P. 110  
L. 240 - P. 110  
L. 260 - P. 110  
L. 280 - P. 110  
L. 280 - P. 110



## NAVARRA

Design: CR&S Riva 1920

Scrivitoio realizzato completamente in legno massello. L'alzata sopra il top comprende due piccoli cassetti, vani a giorno e ripiano superiore per utilizzare al meglio lo spazio disponibile. Il piano scrivania è inoltre dotato di un pratico foro passacavi. Sotto al piano scrivania si trovano tre cassettoni (a richiesta disponibile anche con cassetto unico scorrevole su binari metallici). Articolo disponibile anche nella versione senza cassetti sulla parte superiore.

This writing desk is entirely made of solid wood. The vertical unit above the top includes two small drawers, open-ended spaces and a top shelf to make the best use of the available space. The desk top is also provided with a useful cable hole. Beneath this top there are three small drawers (upon request, it is also available with one single drawer running on metal rails). The article is also available in a version without drawers in the top unit.

Schreibtisch aus Massivholz. Der Aufsatz über der Tischplatte ist mit zwei kleinen Schubladen, offenen Fächern und einem Regal ausgestattet, um den vorhandenen Raum bestmöglich auszunutzen. In der Schreibtischplatte ist außerdem eine praktische Öffnung für Kabeldurchlässe vorgesehen. Unter der Schreibtischplatte befinden sich drei kleine Schubladen (auf Anfrage auch mit einer einzigen Schublade, auf Metallschienen ausziehbar). Der Artikel ist auch ohne Schubladen im Aufsatz erhältlich.

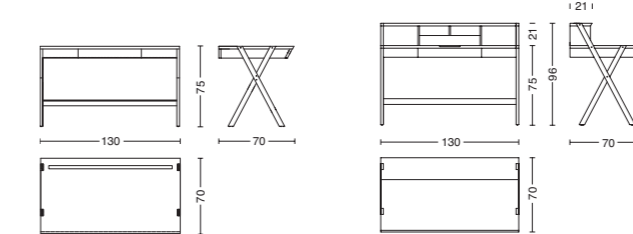

### Cod. 4.07

L. 130 - P. 70 - H. 75/96  
L. 130 - P. 70 - H. 75





## FRAME

Design: CR&S Riva 1920

Consolle in legno massello, dalla forma semplice ed essenziale. L'incastro tra il top e le gambe è impreziosito dalla caratteristica lavorazione a coda di rondine, tipica di un prodotto realizzato artigianalmente.

A console table in solid wood, with simple, essential lines. The connection between the top and the legs features dove-tail joints, a characteristic technique of products built by craftsmen.

Konsole aus Massivholz, einfach und essentiell. Die Verbindung zwischen der Tischplatte und den Tischbeinen wird durch die charakteristische Schwalbenschwanz Verarbeitung bereichert, typisch für ein handgefertigtes Produkt.

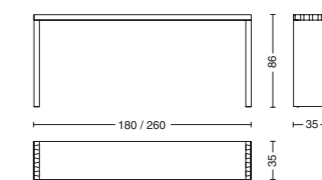

**Cod. FRAME**  
 H. 86 cm. (standard)  
 L. 180 - P. 35  
 L. 200 - P. 35  
 L. 220 - P. 35  
 L. 240 - P. 35  
 L. 260 - P. 35

## ARABESQUE

Design: Luca Scacchetti

Tavolo con gambe e top interamente in legno massello. Un design che, grazie alla caratteristica barra di rinforzo tra le due gambe, ricorda i tipici tavoli "fratini" ma rivisitato da Luca Scacchetti in chiave moderna.

A table with both legs and top made entirely of solid wood. A design which, with its characteristic reinforcing stretcher-bar between the two legs, recalls typical friars' refectory tables, given a modern twist here by Luca Scacchetti.

Tisch mit Tischplatte und Tischbeinen aus Massivholz. Das Design erinnert, dank der charakteristischen Verstärkungsstange zwischen den zwei Tischbeinen, an die typischen "Refektorium" Tische. Das Design wurde von Luca Scacchetti modernisiert.

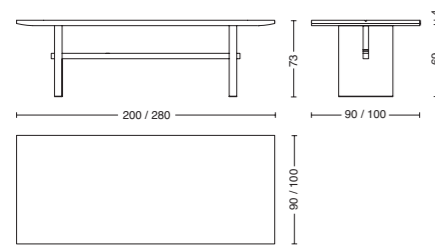

### Cod. ARABESQUE

H. 73 cm. (standard)  
L. 200 - P. 90  
L. 200 - P. 100  
L. 220 - P. 100  
L. 240 - P. 100  
L. 260 - P. 100  
L. 280 - P. 100



## SHERWOOD 2013

Design: CR&S Riva 1920

Tavolo con top spessore 5 cm. e gambe in legno massello. Realizzabile anche su misura disponibile in tutte le essenze a catalogo.

Table with top and base in solid wood. Top thickness 4.8 cm. It can be custom-made and is available in all woods of our range.

Tisch mit 5 cm dicken Tischplatte und Tischbeine aus Massivholz. Erhältlich auch in Sondermaßen und in allen Holzarten des Kataloges.

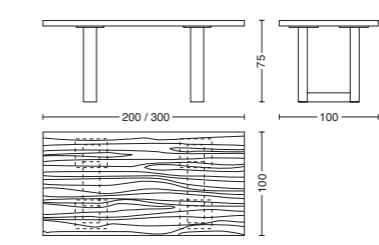

### Cod. 3.56 WOOD

H. 75 cm. (standard)  
L. 200 - P. 100  
L. 220 - P. 100  
L. 240 - P. 100  
L. 260 - P. 100  
L. 280 - P. 100  
L. 300 - P. 100



## COLINO ROUND

Design: Michele De Lucchi

Nuova versione del tavolo Colino rotondo. Top realizzato con una serie di fori dal piacevole effetto decorativo. Base conica in cedro massello che, attraverso una particolare lavorazione con macchine a cinque assi, presenta anch'essa innumerevoli fori decorativi. Il risultato è un tavolo dal design originale in cui l'effetto finale è un gioco di luci e ombre. Disponibile anche nella versione rettangolare e quadrata.

A new version of the Colino round table. The top has a series of holes which create a delightful decorative effect. Thanks to a special process using machines with five axes, the conical solid cedar wood base is realized with innumerable decorative holes. The result is a table with a truly original design whose final effect is a play of light and shadow. Also available in a rectangular and square version.

Eine neue Version des Tisches Colino rotundo. Die Tischplatte weist eine Serie von dekorativen Löchern auf. Auch die konische Basis aus massivem Zedernholz zeigt durch eine besondere Bearbeitung mit einer Fünf-Achs-Maschine zahlreiche dekorative Löcher. Das Ergebnis ist ein Tisch von originellem Design mit einem Licht – Schatten Effekt. Erhältlich auch in rechteckiger und viereckiger Version.

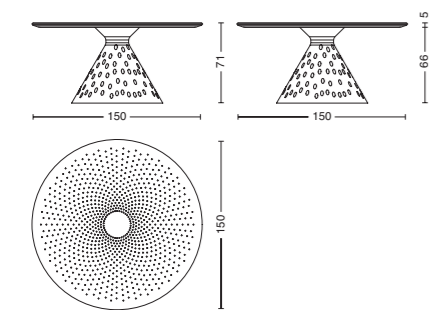

Cod. COLINO R1  
Ø. 150 - H. 71



## PEO

Design: CR&S Riva 1920

Forme arrotondate e sinuose abbinata alla solidità del legno massello sono le caratteristiche principali del tavolo Peo. Il basamento, la gamba centrale e il top, lavorati artigianalmente, trasmettono l'impressione che il tavolo sia realizzato da un unico blocco di legno scolpito. Disponibile nelle misure indicate e in tutte le essenze previste dalla Collezione.

Rounded and sinuous forms combined with the solidity of solid wood constitute the main characteristics of the Peo table. The base, the central leg and the top, all hand-crafted, convey the impression that the table is cut out of a single block of wood. Available in the dimensions indicated and any of the wood types in the Collection.

Die wichtigsten Charakteristika der Tisches PEO sind die abgerundeten und geschwungenen Formen verbunden mit der Solidität des Massivholzes. Das zentrale Tischbein und die Tischplatte, in Handarbeit gefertigt, vermitteln den Eindruck, dass der Tisch aus einem einzigen Holzblock geschnitzt wurde. Erhältlich in den angegebenen Maßen und in allen von der Kollektion vorgesehenen Holzarten.

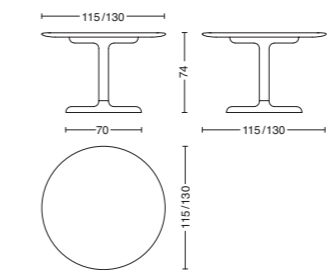

Cod. PEO  
H. 74 cm. (standard)  
Ø. 115  
Ø. 130



# Tavolini

## Small tables

## Couchtische

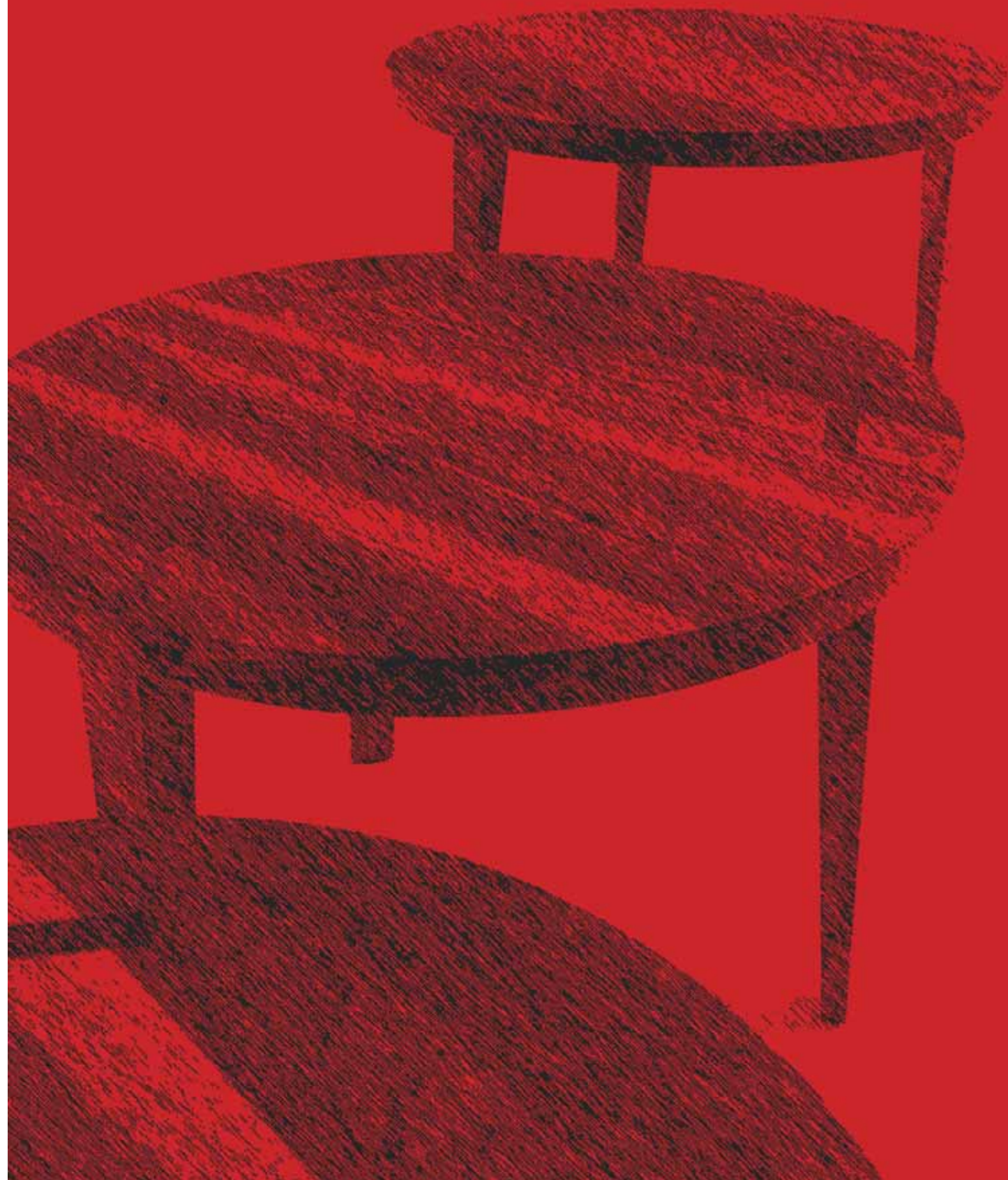

- 43 **TAO**  
DESIGN: CR&S RIVA 1920
- 44 **PEBBLES**  
DESIGN: TERRY DWAN
- 46 **MURITAZE**  
DESIGN: CR&S RIVA 1920
- 46 **LINO - CEDROLINO**  
DESIGN: CLAUDIA GUARDAVACCARO
- 47 **KENOBI**  
DESIGN: BARTOLI DESIGN



### TAO

Design: CR&S Riva 1920

Tavolino con top circolare e gambe in legno massello disponibile in differenti diametri e altezze con la possibilità di essere riposti l'uno sotto l'altro. L'estremità delle gambe, leggere e sottili, sono a vista sul piano. Modello disponibile in tutte le essenze previste dalla Collezione R1920.

Small round topped table with legs in solid wood available in different diameters and heights, with the possibility of placing one under the other. The upper ends of the legs can be seen on the table top. The model is available in all the types of wood on offer in the R1920 Collection.

Kleiner Tisch mit runder Tischplatte und Tischbeinen aus Massivholz, erhältlich in verschiedenen Größen. Die kleinen Tische können untereinander gestapelt werden. Die Endstücke der leichten und schlanken Tischbeine sind auch auf der Tischplatte gut sichtbar. Das Modell ist in allen von der Kollektion R1920 vorgesehenen Holzarten erhältlich.

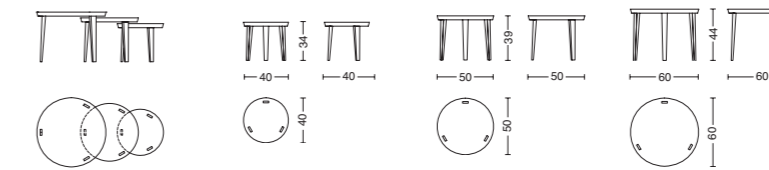

Cod. TAO SMALL  
Ø 40 - H. 34

Cod. TAO 50  
Ø 50 - H. 39

Cod. TAO BIG  
Ø 60 - H. 44







## PEBBLES

Design: Terry Dwan

Tavolini dal design e dalle dimensioni pensate per soddisfare l'esigenza di arredo in spazi pubblici come lounge di hotels o come tavolini da bar. Disponibili con top a forma quadrata, accostabili, e rotondo. La struttura è costituita da una base in ferro laccata grigio antracite "irondust" (standard) o colorata. Disponibile nelle varie essenze previste dalla Collezione.

Tables with a design and dimensions intended to meet the needs of furniture for areas used by the public like hotel lounges or bar tables. Available with a square top - ideal for aggregating tables - or a round top. The structure has an iron base with an anthracite grey "irondust" (standard) or coloured finish. Available in the various types of wood offered by the Collection.

Design und Größe machen aus diesen Tischchen gute Einrichtungselemente für öffentlich genutzte Räumlichkeiten wie die Lounge eines Hotels oder eine Bar bzw. Cafeteria. Das Top in quadratischer Form macht ein Nebeneinanderstellen möglich, es kann aber auch rund ausgeführt werden. Die Struktur besteht aus einem "irondust" anthrazitgrau (Standard) oder farbig lackiertem Untergestell. In den diversen Holzsorten gemäß Kollektion erhältlich.

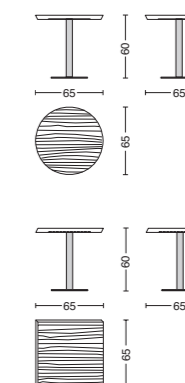

Cod. PEBBLES TONDO  
Ø 65 - H. 60

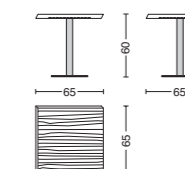

Cod. PEBBLES QUADRATO  
L. 65 - P. 65 - H. 60

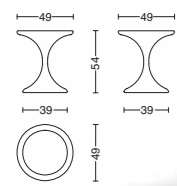

Cod. MURITAZE  
Ø. 49 - H. 54

### MURITAZE

Design: CR&S Riva 1920

Tavolo realizzato completamente in legno massello, con forme arrotondate e sinuose. Il top e la base risultano "fusi" in un unico elemento continuo.

A table made completely of solid wood, with rounded and sinuous forms. The top and the base are "fused" in a distinctive continuous movement.

Tisch aus Massivholz mit runden und geschwungenen Formen. Die Tischplatte und die Basis scheinen zu einem einzigen Element zu "verschmelzen".



### KENOBI

Design: Bartoli Design

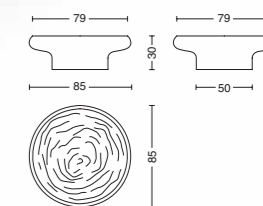

Cod. KENOBI\_SMALL TABLE  
Ø. 79/85 - H. 30

Tavolino nato dall'idea di Bartoli Design. Dalle dimensioni importanti si pone come elemento centrale nella zona living. Della stessa linea è disponibile anche lo sgabello.

Small table inspired by an idea by Bartoli Design. Given its substantial dimensions it becomes a central role in the living area. A stool in the same line is also available.

Ein kleiner Tisch kreiert nach der Idee von Bartoli Design. Wegen seiner Größe ist der Tisch als zentrales Element im Wohnbereich gedacht. Von der gleichen Produktserie sind auch Hocker erhältlich.

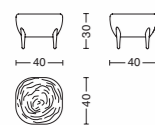

Cod. CEDROLINO  
L. 40 - P. 40 - H. 30

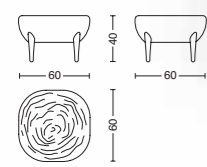

Cod. LINO  
L. 60 - P. 60 - H. 40

### LINO - CEDROLINO

Design: Claudia Guardavaccaro

Divertenti tavolini in cedro disponibili in due diverse dimensioni con gambe sottili in essenza noce che supportano il massiccio blocco in cedro.

Playful cedarwood tables available in two different sizes with thin legs made of walnut that support a block of solid cedarwood.

Kleine sympathische Tische aus Zedernholz in zwei Größen mit schlanken Tischbeinen aus Nussbaum, die den massiven Zedernholz-Block stützen.

# Sedie - Sgabelli - Poltrone - Divani

## Chairs - Stools - Armchairs - Sofas

### Stühle - Hocker - Sessel - Sofas

49	<b>BELGRAVIA</b> DESIGN: CR&S RIVA 1920	66	<b>3D6</b> DESIGN: A. MALGERI E M. ORIGONI	70	<b>LIBRI</b> DESIGN: NATURA COLLECTION BY RIVA
50	<b>VOLTRI</b> DESIGN: STUDIO PIANO DESIGN	66	<b>R313</b> DESIGN: LUCA PEGOLO	70	<b>BIER</b> DESIGN: NATURA COLLECTION BY RIVA
52	<b>SLEEK 2013</b> DESIGN: KARIM RASHID	67	<b>J+I GURURI</b> DESIGN: SHINOBU ITO	70	<b>F1</b> DESIGN: NATURA COLLECTION BY RIVA
53	<b>LOUISE</b> DESIGN: VALERIO COMETTI	67	<b>J+I TSUMIKI</b> DESIGN: KAORI SHIINA	70	<b>BOTTE</b> DESIGN: NATURA COLLECTION BY RIVA
54	<b>KAU</b> DESIGN: CLAUDIO BELLINI	67	<b>J+I CRYSTAL</b> DESIGN: KUNIKO MAEDA	70	<b>VITE BRUGOLA</b> DESIGN: ROBERTO GIACOMUCCI
55	<b>GIOCONDA LEATHER</b> DESIGN: CR&S RIVA 1920	67	<b>J+I CROCCETTA</b> DESIGN: KAZUYO KOMODA	70	<b>DITALE</b> DESIGN: MASSIMO MALACRIDA
56	<b>PIMPINELLA LIGHT</b> DESIGN: RIGOROSO ARBIZZONI	67	<b>J+I ZIG/ZAG</b> DESIGN: SAKURA ADACHI	71	<b>BOLETUS</b> DESIGN: ALESSANDRO MENDINI
57	<b>DAGDA</b> DESIGN: CR&S RIVA 1920	67	<b>J+I SHIFT</b> DESIGN: TOMOKO AZUMI	71	<b>ROCCO</b> DESIGN: ALESSANDRO MENDINI
58	<b>UA UA</b> DESIGN: ANDREA BORGOGNI	68	<b>NOT-RIGID</b> DESIGN: PAOLO SALVADE	71	<b>NANO</b> DESIGN: ELIO FIORUCCI
58	<b>TREMENDA</b> DESIGN: ANDREA BORGOGNI	68	<b>MORESCO</b> DESIGN: FORMFJORD - BAUMANN	71	<b>CUT</b> DESIGN: MARCO ZANUSO JR.
59	<b>BUNGALOW</b> DESIGN: JAMIE DURIE	68	<b>L'EGO</b> DESIGN: ALESSANDRO GUIDOLIN	71	<b>ILDIKO</b> DESIGN: ALEJANDRO RUIZ
59	<b>ROPE</b> DESIGN: JAMIE DURIE	68	<b>KENOBI_STOOL</b> DESIGN: BARTOLI DESIGN	72	<b>PIPA</b> DESIGN: BICUBEDESIGN
60	<b>ELLO</b> DESIGN: FRANCO E MATTEO ORIGONI	68	<b>DJEMBE_STOOL</b> DESIGN: VIOLATO E QUARENGHI	73	<b>WILMA</b> DESIGN: TERRY DWAN
61	<b>DINO</b> DESIGN: TERRY DWAN	68	<b>CHEESE</b> DESIGN: SIMONE CAPPELLO	74	<b>GLOBE</b> DESIGN: PAOLO & JONATHAN NAVA
62	<b>LORD SMALL</b> DESIGN: CR&S RIVA 1920	69	<b>PISTONE</b> DESIGN: NATURA COLLECTION BY RIVA	75	<b>TAFFEE</b> DESIGN: CARLO LEONARDO ROSA
62	<b>BUTTERFLY</b> DESIGN: CR&S RIVA 1920	69	<b>SECCHIOLATTE</b> DESIGN: NATURA COLLECTION BY RIVA	76	<b>FUR NATURE</b> DESIGN: JAMIE DURIE
63	<b>BETTY POUF</b> DESIGN: TERRY DWAN	69	<b>LAMPADINA</b> DESIGN: ALBERTO ALCAMISI	78	<b>UTAH SOFA BRICCOLA</b> DESIGN: CR&S RIVA 1920
64	<b>BARNEY</b> DESIGN: TERRY DWAN	69	<b>SECCHIO</b> DESIGN: NATURA COLLECTION BY RIVA	79	<b>UTAH SOFA</b> DESIGN: CR&S RIVA 1920
65	<b>FIGUS</b> DESIGN: JAMIE DURIE	69	<b>COLA</b> DESIGN: NATURA COLLECTION BY RIVA	80	<b>SKIPPER</b> DESIGN: CR&S RIVA 1920
65	<b>BITTA</b> DESIGN: E. SOLONI, O. REVEZ E A. GRANDE	69	<b>LAVATRICE</b> DESIGN: NATURA COLLECTION BY RIVA		



### BELGRAVIA

Design: CR&S Riva 1920

Dal costante impegno volto all'innovazione da parte del Centro Ricerche e Sviluppo di Riva 1920, nasce una seduta, realizzata completamente in legno massello, dalle linee morbide ed avvolgenti, leggera ed essenziale. Disponibile nelle varie essenze della Collezione.

Thanks to its tireless commitment to innovation, the Riva 1920 Centre for Research and Development has created a chair, made completely of solid wood and characterized by soft, enveloping lines that are both light and simple. Available in all the types of wood offered by the R1920 Collection.

Als Ergebnis einer konstanten, innovativen Forschung des Forschungszentrums Riva 1920 entsteht ein Sitzmöbel aus Massivholz mit weichen und einhüllenden Linien, leicht und essentiell. Erhältlich in den verschiedenen Holzarten der Kollektion.

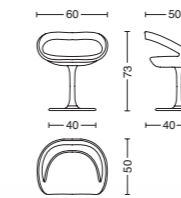

Cod. BELGRAVIA WOOD REVOL

L. 60 - P. 50 - H. 45/73

Cod. BELGRAVIA METAL REVOL

L. 60 - P. 50 - H. 45/73





## VOLTRI

Design: Studio Piano Design

Sedia realizzata completamente in legno massello, assemblata senza l'utilizzo di parti in metallo. La seduta è ergonomica grazie alla lavorazione del sedile d'appoggio e alla inclinazione dello schienale. Questo modello richiama per design e stile la già famosa sedia Piano Design: invariati sono infatti i materiali e le lavorazioni. La nuova versione è caratterizzata dall'abbassamento dello schienale e dall'ampliamento della larghezza della seduta.

A chair made entirely of solid wood and assembled without using metal parts. The chair is ergonomic thanks to the way the supporting seat is made and the angle of the back. This model evokes in its design and style the already famous Piano Design chair: indeed the materials and the processes employed are the same. The distinguishing feature of this new version is the lowering of the back and the increased width of the seat.

Vollständig aus massivem Holz realisierter Stuhl, der ohne die Hilfe metallischer Teile zusammengebaut wurde. Dank der entsprechenden Bearbeitung der Sitzfläche und der Neigung der Rückenlehne ist er ergonomisch. Dies Modell erinnert in seinem Design und Stil an den berühmten Stuhl Piano Design: in der Tat sind Materialien und Bearbeitungen gleich. Die neue Version zeichnet sich dadurch aus, dass die Rückenlehne niedriger und die Sitzfläche breiter sind.

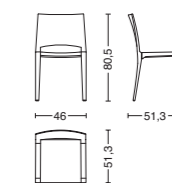

Cod. VOLTRI  
L. 46 - P. 51,3 - H. 80,5

## SLEEK 2013

Design: Karim Rashid

A completamento del progetto della zona living a cura di Karim Rashid, nasce la sedia Sleek, la quale mantiene inalterate le caratteristiche e le linee "minimal" del tavolo Sleek. La leggerezza è la sua dote principale, ottenuta grazie allo "svuotamento" della parte inferiore della seduta. Disponibile nelle varie essenze a catalogo.

A further element for the day-time area being designed by Karim Rashid: the Sleek chair, which maintains the characteristics and "minimal" lines present in the Sleek table. Its foremost quality is lightness, created by "emptying" the lower part of the chair. Available in all the types of wood offered by Catalogue.

Als Ergänzung des Projektes für den Wohnbereich von Karim Rashid entsteht der Stuhl Sleek, der die Charakteristik und die Linie "minimal" des Tisches Sleek unverändert beibehält. Die Leichtigkeit ist sein größter Vorzug, die durch "Aushöhlung" des unteren Teiles der Stuhllehne erzielt wird. Erhältlich in den verschiedenen Holzarten des Kataloges.

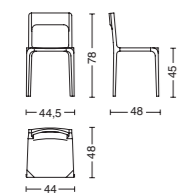
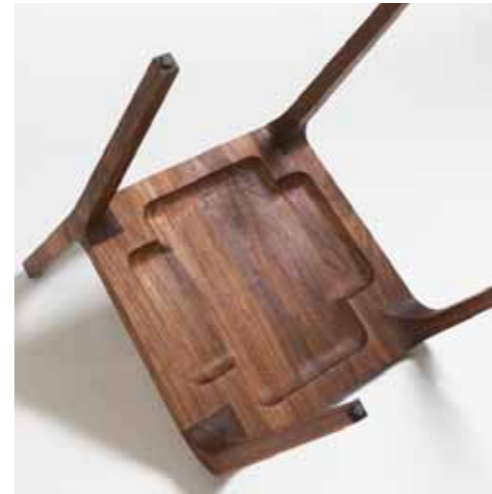

Cod. SLEEK CHAIR  
L. 44,5 - P. 48 - H. 78



## LOUISE

Design: Valerio Cometti

Una sedia nata dal desiderio di grande comfort della seduta, con impiego di materiali di prima scelta: dal legno massello al cuoio e pelli pregiate. La struttura è stata disegnata con l'intenzione di esprimere l'unione tra la robustezza, attraverso le gambe anteriori verticali, e la leggerezza, attraverso lo slancio espresso da quelle posteriori. Le gambe, a sezione variabile, si uniscono in due generosi braccioli.

This seat aims above all at maximum comfort, attained by using only the best quality materials: from the solid wood to the hides and precious leathers. The structure has been designed with the intention of expressing the combination of robustness, thanks to the rising line of the front legs, and lightness, thanks to the verticality expressed by the back legs. The legs, with a variable cross-section, come together in two generous arm-rests.

Aus dem Streben nach mehr Sitz - Komfort und der Verwendung von erstklassigem Material entsteht dieser Sessel: von Massivholz bis zu wertvollem Leder. Die Struktur soll die Verbindung zwischen der Solidität der vorderen, vertikalen Sesselbeinen und der schwungvollen Leichtigkeit der hinteren Sesselbeine zum Ausdruck bringen. Die Sesselbeine verbinden sich mit den zwei großzügigen Armlehnen.

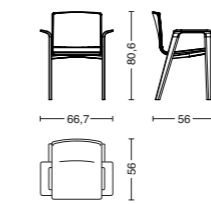

Cod. LOUISE ARMCHAIR  
L. 66,7 - P. 56 - H. 80,6



## KAU

Design: Claudio Bellini

Creata dall'Architetto Claudio Bellini KAU è una sedia leggera, dalla forma semplice, ma particolarmente elegante e curata. KAU è caratterizzata da una struttura in metallo completamente rivestita in cuoio lavorato e cucito a mano. La sedia è disponibile in vari colori presenti nel Campionario "cuoio" mod. Olimpia.

Created by the designer Claudio Bellini, KAU is a light chair of simple form – with a particularly elegant and clean line. KAU is characterised by a metal structure completely covered with "cuoio" hide leather, worked and sewn by hand. The chair comes in various colours offered in the "cuoio" mod. Olimpia sample.

Der von dem Architekten Claudio Bellini kreierte leichte Stuhl KAU hat einfache, aber sehr elegante und gepflegte Formen. KAU ist charakterisiert durch ein Metallgestell, überzogen mit bearbeitetem und von Hand genähtem Kernleder. Der Stuhl ist erhältlich in den verschiedenen Farben des Musterkataloges "Kernleder" mod. Olimpia.

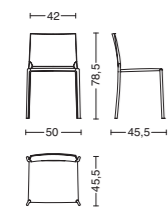

Cod. KAU  
L. 50 - P. 45,5 - H. 78,5



## GIOCONDA LEATHER

Design: CR&S Riva 1920

Sedia con schienale e seduta ricavata interamente da liste in legno massello e incollate fino a formare questa caratteristica forma avvolgente, rivestita in pelle. Base rotonda con gamba centrale girevole in acciaio satinato. Disponibile anche con seduta in legno e base bronzata.

A chair with back and seat made entirely of solid wood planks, glued together to create this distinctive hugging form, covered with leather. Round base with central rotating leg in brushed steel. Also available with a seat in wood and a bronzed base.

Bei diesem Stuhl wurden Rückenlehne und Sitzfläche vollständig aus Massivholzteilen hergestellt, die so verklebt wurden, bis diese charakteristische umhüllende Form erzielt wurde, die dann mit Leder bezogen ist. Rundes drehbares Untergestell aus satiniertem Stahl. Erhältlich auch mit Holzsitzfläche und bronzefarbigem Untergestell.

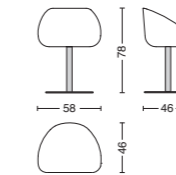

Cod. GIOCONDA LEATHER  
L. 58 - P. 46 - H. 78



## PIMPINELLA LIGHT

Design: Riccardo Arbizioni

Originale rivisitazione della già conosciuta sedia Pimpinella qui presentata con fori regolari sulla seduta e sullo schienale per donare maggiore leggerezza alla sedia.

A highly original re-interpretation of the already well-known Pimpinella chair, presented now with a regular pattern of holes in the seat and back that gives the chair greater lightness.

Originelle Neubearbeitung des schon bekannten Stuhles Pimpinella. Der Stuhl präsentiert sich mit regelmäßigen Löchern in der Sitzfläche und der Rückenlehne, die dem Stuhl einen Anschein von Leichtigkeit verleihen.

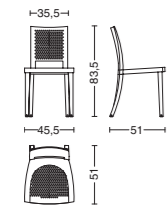

Cod. ARB PIMPINELL 7  
L. 45,5 - P. 51 - H. 83,5



## DAGDA

Design: CR&S Riva 1920

Sedia dal design brioso, costituita da seduta e schienale in legno massello disponibile in tutte le essenze in collezione. La base invece realizzata in ferro laccato opaco (standard in grigio antracite "irondust") è caratterizzata da un design minimale.

A chair with a bold design, with seat and back made of solid wood, available in all the various types of wood offered by the Collection. The base on the other hand is made of iron with an opaque lacquer finish (standard in anthracite grey "irondust") and has a minimalist design.

Stuhl mit beschwingendem Design, Sitzfläche und Rückenlehne aus Massivholz, aus allen in der Kollektion verfügbaren Holzsorten erhältlich. Das Untergestell wird hingegen aus mattschwarzem Eisen hergestellt (Standard in anthrazitgrau "irondust") und zeichnet sich durch minimalistisches Design aus.

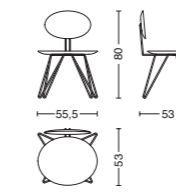

Cod. DAGDA  
L. 55,5 - P. 53 - H. 80



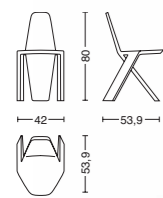

Cod. UA UA

L. 42 - P. 53,9 - H. 80



Sedia dal design non convenzionale con seduta dalla forma esagonale che la rende importante grazie anche allo schienale che prolungandosi fino a terra rende la sedia molto resistente anche alle sollecitazioni più critiche. Disponibile nelle varie essenze a catalogo.

A chair with an un conventional design: a hexagonal seat that gives it substance thanks to its backrest that extends to floor level, a feature that also makes the chair very resistant to all kinds of stress. Available in all the types of wood offered by the Catalogue.

Ein unkonventionelles Design für einen Stuhl mit sechseckiger Sitzfläche, mit einer Rückenlehne, die sich bis zum Boden verlängert und dadurch den Stuhl sehr widerstandsfähig auch für starke Belastungen macht. Erhältlich in den verschiedenen Holzarten des Kataloges.

## UA UA

Design: Andrea Borgogni



## BUNGALOW

Design: Jamie Durie



Più di un semplice sgabello: un vero e proprio oggetto d'arredo. Struttura in legno massello completamente tornita, assemblata e levigata a mano. Seduta ottenuta attraverso l'intreccio di stringhe di pelle "pieno fiore" mod. Utah disponibili in vari colori. A richiesta la seduta può essere realizzata con l'intreccio di pelli di colore diverso così come i dettagli delle cuciture possono essere realizzate con colori a contrasto.

More than a simple stool: a real piece of furniture in a very way. The structure of solid wood is all turned, assembled and smoothed by hand. The chair is realised by interweaving full grain leather straps (mod. Utah) available in various colours. If requested, leather of a different colour from the stitching detail can be used to create a contrast.

Mehr als ein einfacher Hocker: ein Einrichtungsgegenstand. Die Struktur ist aus gedrechseltem Massivholz und von Hand geglättet und zusammengefügt. Die Sitzfläche besteht aus einer Netzbespannung aus Lederstreifen "pieno fiore" mod. Utah, erhältlich in verschiedenen Farben. Auf Anfrage kann die Leder - Netzbespannung mit verschiedenen Farben realisiert werden. Als Detail können die Nähte in Kontrastfarben realisiert werden.

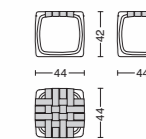

Cod. BUNGALOW

L. 44 - P. 44 - H. 42

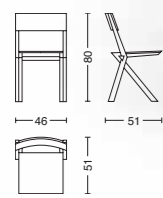

Cod. TREMENDA CHAIR

L. 46 - P. 51 - H. 80



Design e linee semplici per una sedia che ricorda molto la leggerezza di una sedia pieghevole. Realizzata completamente in legno massello è inoltre disponibile in tutte le essenze della Collezione R1920.

A design and line of great simplicity for a chair that immediately brings to mind the lightness of a folding chair. Completely made of solid wood and available in all the types of wood offered by the R1920 Collection.

Das Design und die einfachen Linien dieses Stuhles erinnern sehr an die Leichtigkeit eines Klappstuhles. Vollständig aus Massivholz ist der Stuhl außerdem in allen Holzarten erhältlich.

## TREMENDA

Design: Andrea Borgogni



## ROPE

Design: Jamie Durie



Iconografia del "rocchetto" del sarto, lo sgabello Rope è formato da due elementi naturali quali la corda di canapa, che riveste quasi interamente la struttura dello sgabello e il legno massello, sapientemente abbinati dal design di Jamie Durie per creare un armonioso equilibrio di materiali.

Using the image of the tailor's reel, the Rope stool is formed of two natural elements, hemp rope almost entirely covering the stool's structure and solid wood, intelligently combined by Jamie Durie's design to create a harmonious balance of materials.

Ikongraphie einer "Schneider-spule": der Hocker Rope besteht aus zwei natürlichen Elementen: Hanfseil, das fast zur Gänze die Hocker - Struktur verkleidet und Massivholz. Das Design von Jamie Durie verbindet sehr geschickt die zwei Elemente und kreiert ein harmonisches Gleichgewicht der Materialien.

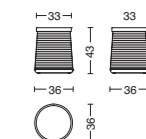

Cod. ROPE\_STOOL

Ø. 36 - H. 43





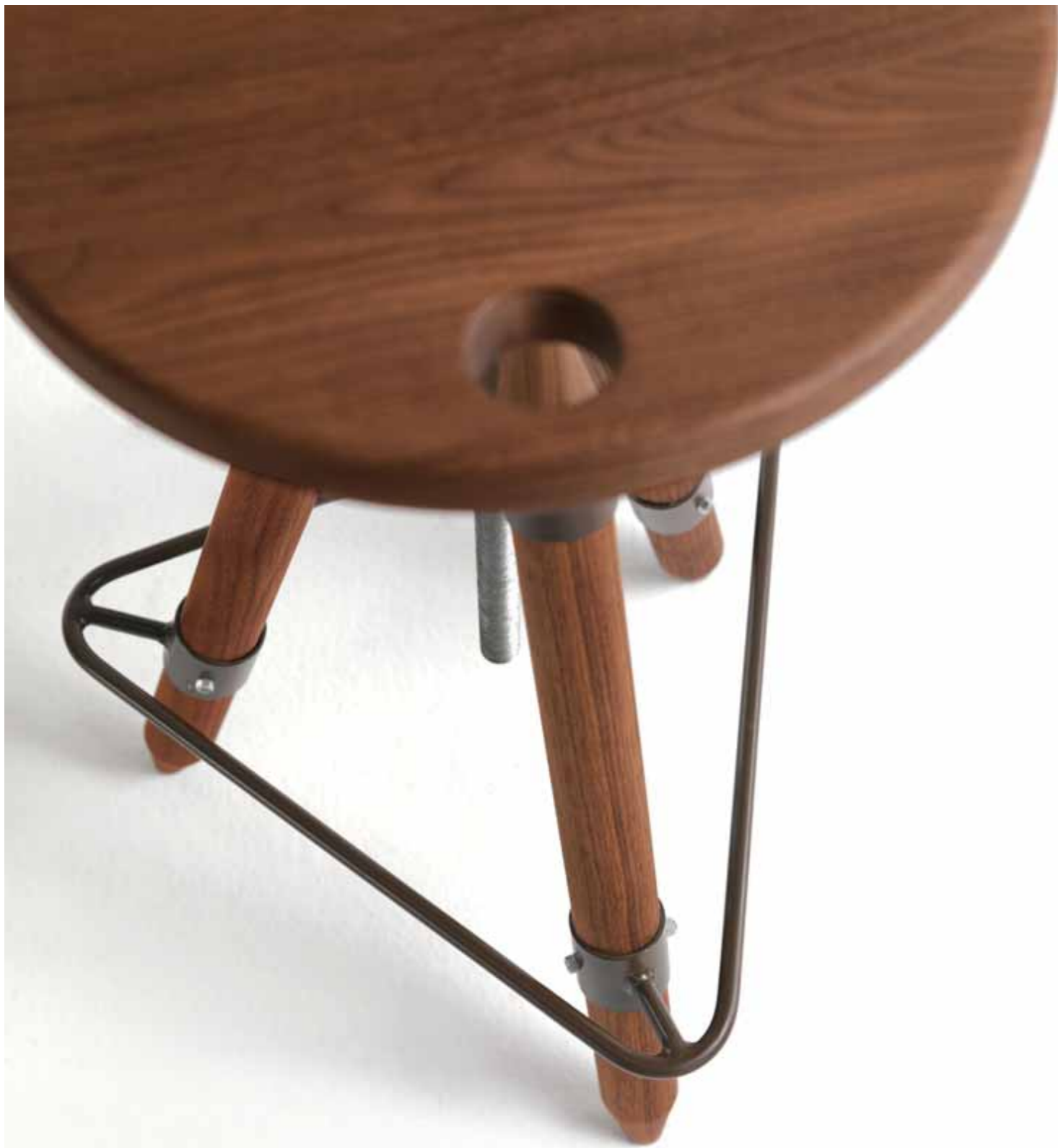

## ELLO

Design: Franco e Matteo Origoni

Sgabello da bar, con seduta girevole e regolabile in altezza. ELLO è il frutto del restyling del progetto originario BRICHELLO disegnato dagli architetti Franco e Matteo Origoni per la collezione "Tra le Briccole di Venezia". Forme semplici e pulite, le stesse che caratterizzano la versione dello sgabello in legno rovere "briccola", sono qui evidenziate sia nella seduta sia nelle tre gambe d'appoggio, in legno massello. Disponibile nelle varie essenze a catalogo.

Bar-stool with height adjustable revolving seat. ELLO is the outcome of restyling the BRICHELLO project designed by Franco and Matteo Origoni for the "Tra le Briccole di Venezia" (Marker posts of the Venice Lagoon) Collection. Its simple, clean lines characterise this version of the stool made of "briccole" oak and are here underlined both in the seat and in the three solid wood supporting legs. Available in all the types of wood offered by the Catalogue.

Barhocker mit Drehsitz und in der Höhe verstellbar. Ello ist das Ergebnis eines restyling des Originalprojektes BRICHELLO der Architekten Franco und Matteo Origoni für die Kollektion "Tra le Briccole di Venezia". Schlichte und saubere Formen, dieselben, die die Hocker-Version aus Eiche "Briccola" charakterisieren. Hier sichtbar sowohl in der Form der Sitzfläche als auch in der Form der drei Hocker-Beinen, aus Massivholz. Erhältlich in den verschiedenen Holzarten des Kataloges.

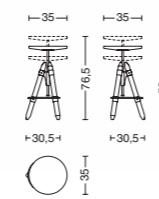

Cod. ELLO  
Ø 35 - H. 58/76,5

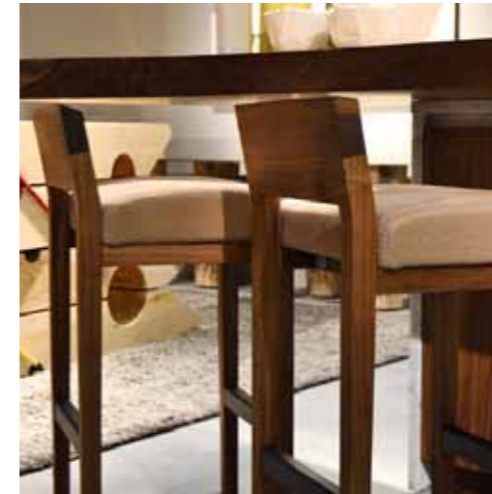

## DINO

Design: Terry Dwan

Ispirato al design della panca Betty, nasce Dino, sgabello da bar con le stesse caratteristiche: legno massello con schienale che evidenzia il bordo naturale, seduta imbottita in pelle nabuccata Utah. Lo sgabello è inoltre corredato da profili in metallo poggiapiedi utili per proteggere i listelli di legno della struttura.

Dino takes its inspiration from the design of the Betty bench. A bar stool boasting the same characteristics: solid wood with a back that emphasises its natural edge, an upholstered seat covered in nubuck leather, aging effect, mod. Utah. The stool also has useful metal footrests which offer protection to the wood of the structure.

Am Design der Bank Betty inspiriert, entsteht Dino. Ein Barhocker mit den gleichen Charakteristiken: Massivholz mit Rückenlehne und Hervorhebung des naturbelassenen Randes, gepolsterte und mit Nubukleder Utah bezogene Sitzfläche. Der Hocker ist außerdem mit Metallprofilen zum Aufsetzen der Füße versehen um das Holz der Struktur zu schonen.

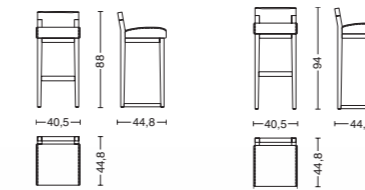

DINO 1  
L. 40,5 - P. 44,8 - H. 88

DINO 2  
L. 40,5 - P. 44,8 - H. 94





Un elemento multifunzionale grazie alla sua seduta asportabile: tavolino, sgabello o pouf abbinabile a una poltrona. Dotato di un vano contenitore sotto la seduta, è caratterizzato da una struttura in legno formata da tanti piccoli listelli che creano un effetto molto particolare tipico di un prodotto il legno massello. Lord small è disponibile con struttura solo in legno massello di noce e seduta in pelle nabuccata mod. Utah, nei colori disponibile dal Campionario pelli.

A multifunctional element thanks to its removable seat: A small table, stool and a pouf that can be combined with an armchair. The table has a storage space under the seat and features a wooden structure made up of lots of small strips that create a most unusual effect typical of a product made of solid wood. Lord Small is available with a structure only in solid walnut and a seat in full grain leather mod. Utah; in all the colours available in the leather sample card.

Ein Vielzweckelement dank seiner abnehmbaren Sitzfläche: Kleiner Tisch oder Hocker. Unter der Sitzfläche mit einem Fach ausgestattet; dieses Element ist charakterisiert durch eine Holzstruktur aus vielen kleinen Stäben, die einen besonderen Effekt, typisch für ein Massivholzprodukt, kreiert. Lord Small ist erhältlich mit einer Struktur aus Nussbaum Massivholz und Sitzfläche aus Nubuk Leder mod. Utah in den vom Katalog für Leder vorgesehene Farben.

## LORD SMALL

Design: CR&S Riva 1920



## BUTTERFLY

Design: CR&S Riva 1920

Dalla ricerca per la leggerezza nasce lo sgabello Butterfly, dotato di una seduta rivestita in pelle nabuccata effetto invecchiato mod. Utah, caratterizzata da linee arrotondate e morbide. Struttura in ferro laccato disponibile in colori a scelta come da campionario.

The Butterfly stool is the result of our search for lightness. Its seat is covered in nubuck aging effect hide leather "mod. Utah" and distinguished by its soft, rounded lines. The structure in lacquered iron is available in the colours offered by our sample card.

Aus der Suche nach Leichtigkeit stammt der Hocker Butterfly, dessen Sitzfläche mit Nubukleder mit Alterungseffekt Mod. Utah bezogen wurde und die sich durch abgerundete und weiche Linien auszeichnet. Struktur aus lackiertem Eisen mit Farbe gemäß Musterbuch.

## BETTY POUF

Design: Terry Dwan



Dall'idea della Panca mod. Betty, Terry Dwan disegna Betty pouf. Sgabello con imbottitura morbida e rivestimento in pelle nabuccata effetto invecchiato mod. Utah, lavorato e cucito a mano. Betty pouf vuole essere un complemento per la produzione Riva 1920: una seduta in pelle abbinabile facilmente alla produzione di tavoli o scrivanie in legno massello. La forma del rivestimento morbido ed affusolato, caratterizzato da doppie cuciture angolari, lo rendono un prodotto semplice ma ricco di dettagli tipici di un prodotto artigianale. La nuova versione "Betty Pouf Small" è invece più squadrata perché ridotta in altezza, permettendo di inserire questo complemento anche in zone lounge o in abbinamento a piccoli tavoli e divani.

Based on the idea of the "Betty bench", Terry Dwan has designed the Betty pouf. Soft upholstery covered in nubuck aging effect hide leather "mod. Utah", worked and sewn by hand. The Betty pouf is conceived as an accessory for Riva 1920 products: a leather seat that can be a companion piece to many solid wood tables or desks. The soft tapering form of the covering, featuring angled double seams, makes it a product of simplicity but still rich in detailing typical of an artisanal product. The new version "Betty Pouf Small" is more square because it is lower, making it suitable also for lounge areas or being combined with small tables and sofas.

Auf Basis des Bankmodells Betty entwirft Terry Dwan den Hocker Betty. Weich gepolsterter Hocker mit Bezug aus Nubukleder mit Alterungseffekt Mod. Utah, von Hand bearbeitet und genäht. Der Hocker Betty versteht sich als ergänzendes Element der Produkte von Riva 1920: Ein Leder-sitz, der sich leicht mit Tischen oder Schreibtischen aus Massivholz kombinieren lässt. Die Form des weichen und zulaufenden Bezugs, der an den Kanten Doppelnähte aufweist, machen aus ihm ein einfaches aber detailhaltiges Produkt, typisch für handwerkliche Fertigung. Der "Betty Hocker Small" ist hingegen quadratischer, da er etwas niedriger ist, passt auch in Lounge Bereiche und kann gut mit kleinen Tischen und Sofas kombiniert werden.

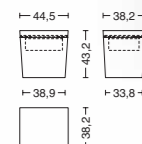

Cod. LORD SMALL

L. 44,5 - P. 38,2 - H. 43,2

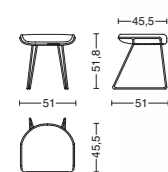

Cod. BUTTERFLY\_LEATHER

L. 51 - P. 51 - H. 51,8

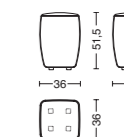

Cod. BETTY-POUF

L. 36 - P. 36 - H. 51,5

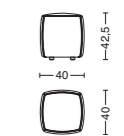

Cod. BETTY-POUF-SMALL

L. 40 - P. 40 - H. 42,5



## BARNEY

Design: Terry Dwan



Sgabello realizzato con una struttura in ferro laccato trasparente opaco e seduta rivestita in pelle pieno fiore mod. "Utah". Disponibile in due versioni – Barney Small e Barney Big – che differiscono per l'altezza della seduta. Barney Big è ideale come sgabello per piani snack da cucina o anche per bar e bistrot.

A stool featuring a structure in matt transparent lacquered iron and a seat covered in full grain leather mod. "Utah". Available in two versions – Barney Small and Barney Big – that have different seat heights. Barney Big is ideal as a stool for kitchen snack counters or even for bars and bistrots.

Hocker mit einer Struktur aus matt transparent lackiertem Eisen und einer mit Leder (mod. "Utah") bezogenen Sitzfläche. Erhältlich in zwei Versionen – Barney Small und Barney Big – von unterschiedlicher Sitzhöhe. Barney Big ist ideal als Hocker für eine Küchenhalbinseln oder auch für eine Bar oder ein Bistro.

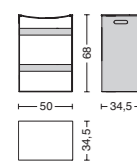

**BARNEY BIG**  
L. 50 - P. 34,5 - H. 68

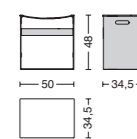

**BARNEY SMALL**  
L. 50 - P. 34,5 - H. 48



## FIGUS

Design: Jamie Durie

Dall'estro del designer australiano Jamie Durie nasce uno sgabello in cedro che ricorda la sezione stilizzata di un tronco d'albero.

The bold imagination of Australian designer Jamie Durie has created a stool in cedarwood which evokes the stylised section of a tree trunk.

Aus einer Inspiration des australischen Designers Jamie Durie entsteht ein Hocker aus Zedernholz, der an eine stilisierte Sektion eines Baumstammes erinnert.

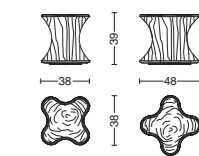

**Cod. FIGUS**  
L. 38/48 - P. 38/48 - H. 39



## BITTA

Design: Elena Soloni, Omri Revesz e Alessandro Grande

Seduta ispirata ai tradizionali punti di ormeggio per le barche visibili in molti porti e nella laguna di Venezia e non solo. Lo sgabello è composto da due elementi principali: una porzione in legno massello, sagomata per creare la seduta, e un basamento in ferro naturale oliato, presentato in due altezze diverse. Realizzabile esclusivamente in cedro.

A seat inspired by the traditional boat mooring points that can be seen in many ports and in the Venice lagoon. The stool is made up of two main elements: one part solid wood, cut to create the seat, and a natural iron base with an oil finish. It comes in two different heights. Available exclusively in cedarwood.

Dieser Hocker inspiriert sich an den traditionellen Bootsanlegepunkten, die man in vielen Häfen und der venezianischen Lagune sehen kann. Er besteht aus zwei Hauptelementen: ein Teil aus massivem Holz, das entsprechend geformt den Sitz bildet, und aus einem Untergestell aus geöltem Roheisen; in zwei unterschiedlichen Höhen verfügbar. Nur aus Zedernholz erhältlich.

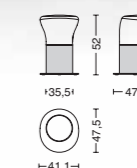

**Cod. BITTA BIG**  
L. 35,5 - P. 47,5 - H. 52

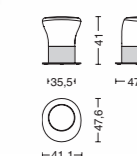

**Cod. BITTA SMALL**  
L. 35,5 - P. 47,6 - H. 41

### 3d6

Design: Andrea Malgeri e Matteo Origoni



Sgabello multifunzione realizzato in legno massello di cedro. A seconda della sua posizione, 3d6 può essere utilizzato come sgabello alto, poltrona singola, poltrona con seduta più ampia o come tavolino.

A multifunctional stool made of solid cedarwood. Depending on its position, 3d6 can be used as a high stool, a single armchair, armchair with a wide seat or as a small table.

Ein Vielzweck – Hocker aus massivem Zedernholz. Je nach seiner Positionierung kann der Hocker 3d6 als Barhocker, einsitziger Sessel, Sessel mit erweiterter Sitzfläche oder als Tisch verwendet werden.

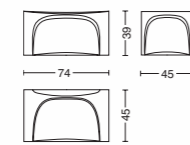

Cod. TREDISEI  
L. 74 - P. 39 - H. 45

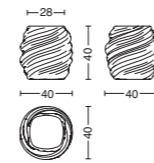

**J+I GURURI**  
Design: Shinobu Ito  
Cod. J+I GURURI  
Ø. 40 - H. 40

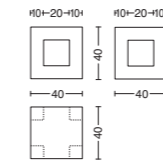

**J+I TSUMIKI**  
Design: Kaori Shiina  
Cod. J+I TSUMIKI  
L. 40 - P. 40 - H. 40

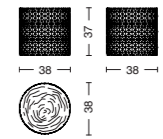

**J+I CRYSTAL**  
Design: Kuniko Maeda  
Cod. J+I CRYSTAL  
Ø. 38 - H. 37



### R313

Design: Luca Pegolo

"Tronco a rotelle", macchina cavalcabile per bambini ricavata da un tronco di cedro. Una vera esperienza materica per i più piccoli: una texture ed un profumo indimenticabili...

"Trunk on wheels", a vehicle for children to straddle, cut from a trunk of cedarwood. A really tactile experience for the very young: an unforgettable texture and fragrance...

"Baumstamm mit Rädern" Rutsch-wagen für Kinder gewonnen aus einem Baumstamm aus Zedernholz, eine reale Materialerfahrung für die Kleinsten: eine unvergessliche Textur und ein unvergesslicher Duft.....

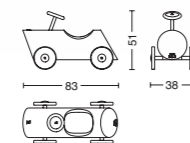

Cod. R313 MICRO  
L. 83,2 - P. 38 - H. 50,8

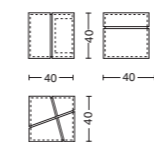

**J+I CROCETTA**  
Design: Kazuyo Komoda  
Cod. J+I CROCETTA  
L. 40 - P. 40 - H. 40

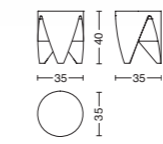

**J+I ZIG/ZAG**  
Design: Sakura Adachi  
Cod. J+I ZIG ZAG  
Ø. 35 - H. 40

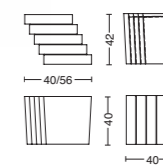

**J+I SHIFT**  
Design: Tomoko Azumi  
Cod. J+I SHIFT  
L. 40/56 - P. 40 - H. 42

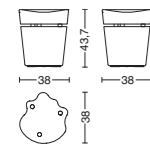

**NOT-RIGID**  
Design: Paolo Salvadè  
Cod. NOT-RIGID  
L. 38 - P. 38 - H. 43,7

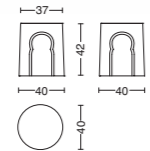

**MORESCO**  
Design: Formford - Baumann  
Cod. MORESCO  
Ø. 40 - H. 42

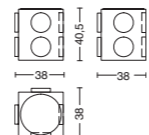

**L'EGO**  
Design: Alessandro Guidolin  
Cod. L'EGO  
L. 38 - P. 38 - H. 40,5

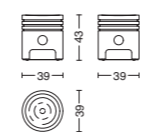

**PISTONE**  
Design: Natura Collection by RIVA  
Cod. PISTONE  
Ø 39 - H. 43

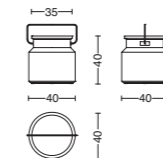

**SECCHIOLATTE**  
Design: Natura Collection by RIVA  
Cod. SECCHIOLATTE  
Ø 40 - H. 40

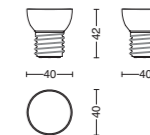

**LAMPADINA**  
Design: Alberto Alcamisi  
Cod. LAMPADINA  
Ø 40 - H. 42

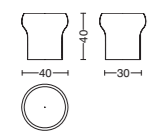

**KENOBI\_STOOL**  
Design: Bartoli Design  
Cod. KENOBI\_STOOL  
Ø. 40 - H. 40

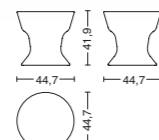

**DJEMBE\_STOOL**  
Design: Violato e Quarenghi  
Cod. DJEMBE\_STOOL  
Ø. 44,7 - H. 41,9

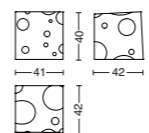

**CHEESE**  
Design: Simone Cappello  
Cod. CHEESE  
L. 41 - P. 42 - H. 40



**SECCHIO**  
Design: Natura Collection by RIVA  
Cod. SECCHIO  
Ø 45 - H. 40

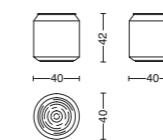

**COLA**  
Design: Natura Collection by RIVA  
Cod. COLA  
Ø 40 - H. 42

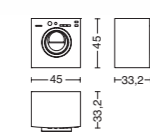

**LAVATRICE**  
Design: Natura Collection by RIVA  
Cod. LAVATRICE  
L. 45 - P. 33,2 - H. 45

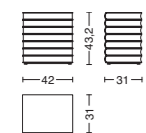

### LIBRI

Design: Natura Collection by RIVA

Cod. LIBRI

L. 42 - P. 31 - H. 43,2

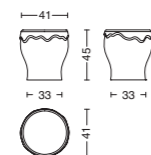

### BIER

Design: Natura Collection by RIVA

Cod. BIER

Ø 41 - H. 45

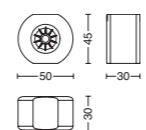

### F1

Design: Natura Collection by RIVA

Cod. F1

L. 50 - P. 30 - H. 45

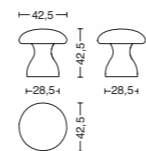

### BOLETUS

Design: Alessandro Mendini

Cod. BOLETUS

Ø 42,5 - H. 42,5

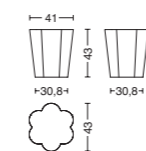

### ROCCO

Design: Alessandro Mendini

Cod. ROCCO

Ø 41 - H. 43



### NANO

Design: Elio Fiorucci

Cod. NANO\_FIORUCCI

L. 25,2 - P. 22,2 - H. 45,5

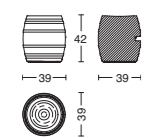

### BOTTE

Design: Natura Collection by RIVA

Cod. BOTTE

Ø 39 - H. 42

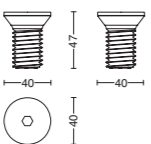

### VITE BRUGOLA

Design: Roberto Giacomucci

Cod. VITE BRUGOLA

Ø 40 - H. 47

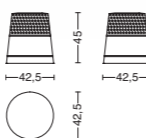

### DITALE

Design: Massimo Malacrida

Cod. DITALE

Ø 42,5 - H. 45

### CUT

Design: Marco Zanuso Jr.

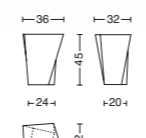

Cod. CUT 1

L. 36 - P. 32 - H. 45

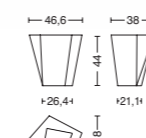

Cod. CUT 2

L. 46,6 - P. 38 - H. 44

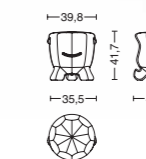

### ILDIKO

Design: Alejandro Ruiz

Cod. ILDIKO

L. 39,8 - P. 40,6 - H. 41,7

## PIPA

Design: Bicubedesign

Dalla nuova collaborazione con Bicubedesign nasce uno sgabello in cedro che ricorda la PIPA il classico tipo di pasta di origine campana. Ricavato da un tronco intero di cedro, macchinari ad alta tecnologia gli conferiscono questa particolare forma a guscio di lumaca.

This stool in cedarwood is fruit of a new collaboration with Bicubedesign. The form reminds one of PIPA, the classic pipe-shaped pasta from Campania. Cut from an entire trunk of cedarwood, it takes on its snail-shell shape thanks to a process involving high technology machines.

Aus der neuen Zusammenarbeit mit Bicubedesign entsteht ein Zedernholzocker, der an das klassische kampanische Nudelformat PIPA erinnert. Dieser Hocker wird aus einem Zedernholzstamm herausgearbeitet und Hightech Maschinen verleihen ihm die besondere Schneckenhausform.

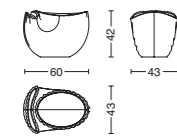

Cod. PIPA  
L. 60 - P. 43 - H. 42



## WILMA

Design: Terry Dwan

Dal successo della panca Betty, la designer americana Terry Dwan disegna la poltroncina Wilma, pensata principalmente per contract nel mondo dell'hospitality. Una poltrona che racchiude al suo interno tutte le qualità distintive di un oggetto, di grande comfort e resistenza, pensato per gli spazi pubblici. Wilma è realizzata in legno massello di noce (come in foto) ma disponibile anche in altre essenze con seduta imbottita in pelle nabuccata effetto invecchiato mod. Utah. La poltroncina Wilma è disponibile sia nella versione senza braccioli sia nella versione con braccioli.

Following the success of the Betty bench, the American designer Terry Dwan has designed Wilma, a chair destined mainly for the contract sector of the hospitality industry. An armchair that embraces all the distinctive qualities of an object of great comfort and robustness, designed with public spaces in mind. Wilma is made of solid walnut (see photo) but is also available in other types of wood: the padded seat is in nubuck leather, aging effect mod. Utah. Wilma is available in both a version without armrests and one with.

Nach dem Erfolg der Bank Betty entwirft die amerikanische Designerin Terry Dwan das Sesselchen Wilma, das hauptsächlich für das Hotel- und Gaststättengewerbe gedacht ist. Ein Sesselchen, das alle kennzeichnenden Qualitäten eines Gegenstandes wie Komfort und Robustheit in sich vereint und für öffentlich genutzte Räumlichkeiten gedacht ist. Wilma wird aus massivem Nussbaumholz hergestellt (wie im Foto), steht aber auch in anderen Holzsorten zur Verfügung, Sitzfläche gepolstert und bezogen mit Nubukleder mit Alterungseffekt Mod. Utah. Das Sesselchen ist sowohl mit als auch ohne Armlehne erhältlich.

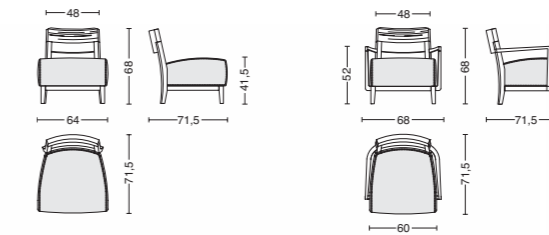

Cod. WILMA  
L. 64 - P. 41,5 - H. 68

Cod. WILMA/B LEGNO  
L. 68 - P. 41,5 - H. 68



## GLOBE

Design: Paolo & Jonathan Nava

Comoda e singolare poltrona realizzata in cedro profumato del Libano e nata dall'estro e dalla creatività di Paolo e Jonathan Nava. Globe presenta una seduta ergonomica e una base girevole in ferro naturale. Su richiesta può essere accompagnata dai rispettivi Globe Pouff, anch'essi in cedro massello.

Globe is a comfortable and distinctive armchair made of solid scented cedarwood, an expression of the originality and creativity of its designers, Paolo and Jonathan Nava. It has an ergonomic seat and a natural iron revolving base. Available on request with Globe Pouff also in solid cedarwood.

Globe ist ein bequemer und origineller Sessel aus duftendem und massivem Holz der Libanonzeder und ein Ergebnis der Phantasie und Kreativität von Paolo und Jonathan Nava. Mit ergonomischem Sitz und drehbarem Gestell aus Roheisen. Auf Anfrage steht er auch mit den Globe Hocker zur Verfügung, auch diese sind aus massivem Zedernholz.

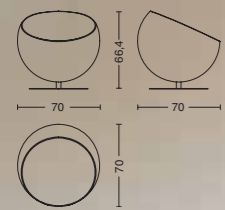

Cod. GLOBE CHAIR  
L. 70 - P. 70 - H. 66,4

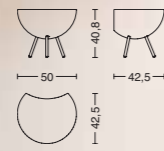

Cod. GLOBE POUFF  
L. 50 - P. 40,8 - H. 42,5



## TAFFEE

Design: Carlo Leonardo Rosa

Poltrona ottenuta dalla lavorazione di un unico tronco di cedro. Caratterizzata da una stravagante forma a "tazza" diventa una comoda seduta grazie al cuscino in pelle e allo schienale avvolgente in legno massello.

Armchair obtained by working a single trunk of cedarwood. Distinguished by an extraordinary cup-shape, it turns into a comfortable seat thanks to a leather cushion and to the solid wood curved back.

Sessel gewonnen aus der Bearbeitung eines einzigen Baumstammes aus Zedernholz. Die extravagante "Tassen" Form bietet einen bequemen Sitz mit Lederkissen und eine "umhüllenden" Rückenlehne, aus Massivholz.

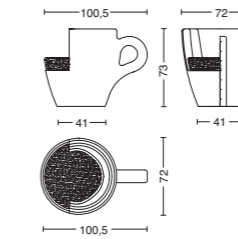

Cod. TAFFEE  
L. 100,5 - P. 72 - H. 73







## FUR NATURE

Design: Jamie Durie

Divano con imbottitura morbida e rivestimento in pelle nabuccata effetto invecchiato mod. Utah, lavorato e cucito a mano. Realizzabile "su misura" e modificabile in varie configurazioni grazie ai moduli disponibili. Basi, schienali, braccioli, cuscini, pouf sono alcuni degli elementi principali con i quali si può "giocare" per creare il proprio divano ideale.

A sofa with soft upholstery covered in nubuck aging effect hide leather mod. Utah, worked and sewn by hand. "Made-to-measure" sofa that can be reconfigured thanks to the available modules. Bases, backs, armrests, cushions, poufs – these are some of the main units that you can "play" with to create your own ideal sofa.

Weich gepolstertes Sofa mit Bezug aus Nubukleder mit Alterungseffekt Mod. Utah, von Hand bearbeitet und genäht. Kann dank der verfügbaren Module "nach Maß" und in diversen Konfigurationen angefertigt werden. Untergestell, Rückenlehne, Armlehnen, Kissen und Hocker sind einige der Elemente, mit denen man "spielen" kann um sich sein ideales Sofa zusammenzustellen.

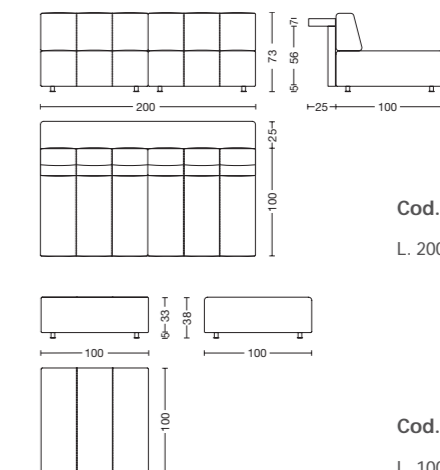

Cod. FUR NATURE PROJECT 1  
L. 200 - P. 125 - H. 38/73

Cod. FUR NATURE\_POUF A  
L. 100 - P. 100 - H. 38

## UTAH SOFA BRICCOLA

Design: CR&S Riva 1920

Divano nato dalla creatività dei fratelli Riva, con base realizzata interamente in legno massello e rivestito con pelle nabuccata effetto invecchiato. Comodo ed elegante, è realizzabile in diverse composizioni, anche nella versione angolare. La struttura è disponibile nelle essenze a catalogo ed anche nella caratteristica versione in rovere "Briccole" di Venezia attraverso l'utilizzo di sezioni di pali.

An expression of the creativity of the Riva brothers, this sofa has a base made completely of solid wood and covered in nubuck aging effect hide leather. Comfortable and elegant, it is available in various arrangements, including an angular version. The structure is available in all the woods in our catalogue as well as in the striking oak "Briccole di Venezia" version by using cut sections of the marker posts.

Dieses Sofa entstammt der Kreativität der Gebrüder Riva, das Untergestell wird vollständig aus Massivholz angefertigt und der Bezug aus Nubukleder mit Alterungseffekt. Bequem und elegant kann es in diversen Arrangements ausgeliefert werden, auch als Eckversion. Die Struktur ist in den Holzsorten gemäß Katalog zu haben, auch in der charakteristischen Eichenversion "Briccole di Venezia", bei der Pfahlabchnitte verwendet werden.



## UTAH SOFA

Design: CR&S Riva 1920

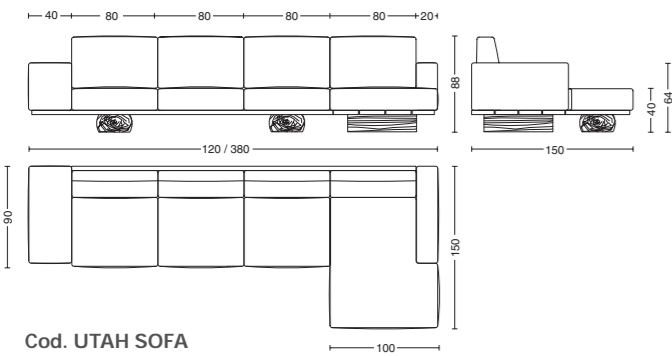

Cod. UTAH SOFA

L. 120/380 - P. 90/150 - H. 40/88

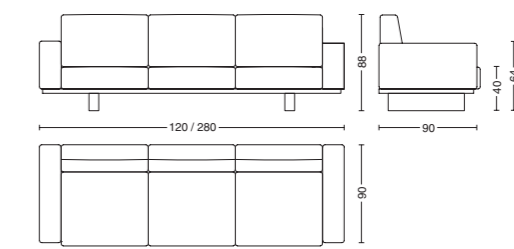

Cod. UTAH SOFA

H. 40/88  
L. 120 - P. 90  
L. 200 - P. 90  
L. 280 - P. 90





## SKIPPER

Design: CR&S Riva 1920

Divano componibile sulla base delle diverse esigenze d'arredo accostando i diversi moduli. Rivestimento in pelle nabuccata effetto invecchiato mod. Utah nei colori presenti a catalogo. Le cuciture della pelle poste volutamente in evidenza agli angoli dei vari elementi che costituiscono il divano, sono standard realizzate tono su tono. A richiesta possono essere realizzate con colori a contrasto. A richiesta inoltre il rivestimento del divano è disponibile in tessuto o con materiali su misura per il cliente.

Modular sofa that can be arranged to meet varying needs by assembling the different modules. Covered in nubuck aging effect hide leather "mod. Utah", in the colours offered in the catalogue. The seams of the leather are given emphasis along the edge of the elements making up the sofa. Standard versions are made in uniform shades, but contrasting colours can be used if requested. Fabric covering is also available or using material supplied by the customer.

Bei diesem Sofa können die diversen Module je nach Bedarf entsprechend zusammengestellt werden. Der Bezug aus Nubukleder mit Alterungseffekt Mod. Utah ist in den Farben gemäß Katalog zu haben. Die Nähte an den Kanten der diversen Sofaelemente sind gewollt gut sichtbar und werden serienmäßig Ton in Ton ausgeführt. Auf Wunsch können sie jedoch auch in einer Kontrastfarbe realisiert werden. Auf Anfrage ist der Sofabezug auch aus Stoff oder aus einem Wunschmaterial des Kunden zu haben.

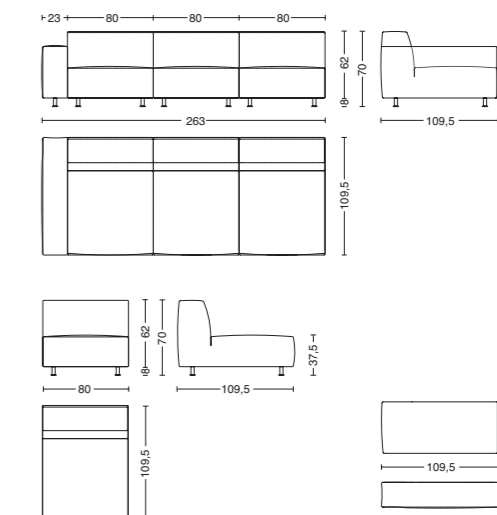

Cod. SKIPPER 3.1BL  
L. 263 - P. 109,5 - H. 37,5/70

Cod. SKIPPER 1  
Modulo singolo componibile  
Modular sofa unit  
Einzelnes Modul

Cod. SKIPPER B  
Bracciolo  
Armrest  
Armlehne

# Panche Benches Bänke

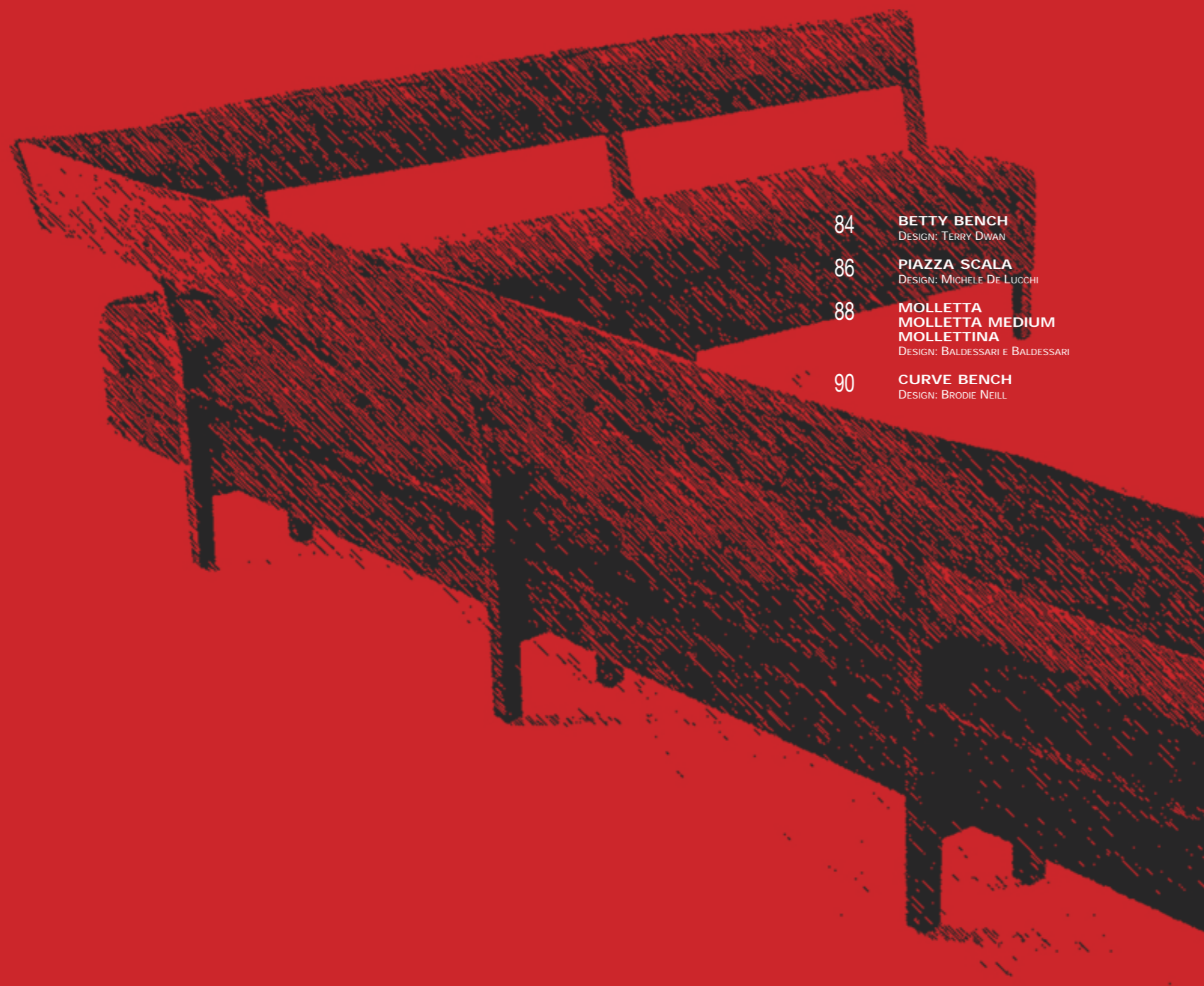

84

**BETTY BENCH**  
DESIGN: TERRY DWAN

86

**PIAZZA SCALA**  
DESIGN: MICHELE DE LUCCI

88

**MOLLETTA**  
**MOLLETTA MEDIUM**  
**MOLLETTINA**  
DESIGN: BALDESSARI E BALDESSARI

90

**CURVE BENCH**  
DESIGN: BRODIE NEILL





## BETTY BENCH

Design: Terry Dwan

Nata dall'estro e dalla creatività dell'architetto Terry Dwan, Betty è una panca completamente fatta e assemblata artigianalmente nella quale viene messo in evidenza lo schienale che esalta le forme naturali del legno massello e la morbida seduta con cuscini foderati e cuciti su misura. Disponibile in varie lunghezze o ad angolo. Seduta rivestita in pelle nabuccata effetto invecchiato mod. Utah nei colori presenti a catalogo.

Designer Terry Dwan's bold imagination finds expression here; Betty is a bench completely crafted and assembled individually, featuring a back which emphasises the natural forms of the solid wood and a soft seat with cushions that have been upholstered and sewn to order. Available in various lengths, and as an L-shaped structure. Seat in nubuck aging effect hide leather "mod. Utah", in the colours offered in the catalogue.

Phantasie und Kreativität der Architektin Terry Dwan standen Pate beim Bankmodell Betty. Diese Bank wird vollständig von Hand angefertigt und zusammengesetzt. Die auffällige Rückenlehne unterstreicht die natürlichen Formen des massiven Holzes und optisch hervorgehoben wird auch die weiche und mit maßgeschneiderten Kissen ausgepolsterte Sitzfläche. Ist in unterschiedlichen Längen und auch als Eckmodell zu haben. Sitzflächenbezug aus Nubukleder mit Alterungseffekt Mod. Utah in den Farben gemäß Katalog.

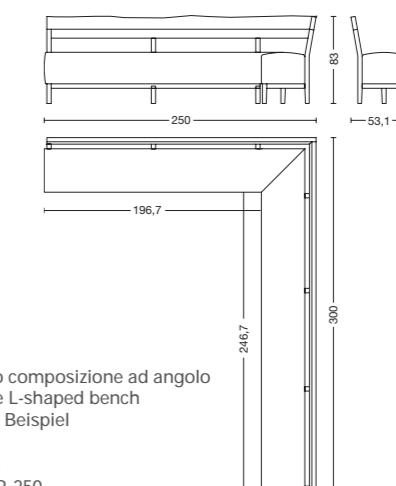

Esempio composizione ad angolo  
Example L-shaped bench  
Eckbank Beispiel

H. 51/83  
L. 300 - P. 250

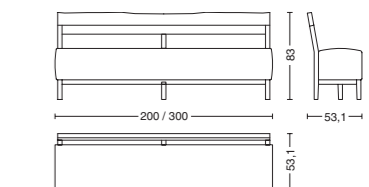

Cod. BETTY-BENCH

H. 51/83  
L. 200 - P. 53,1  
L. 250 - P. 53,1  
L. 300 - P. 53,1



## PIAZZA SCALA

Design: Michele De Lucchi

Panca realizzata completamente in legno massello. Inconfondibile il design di Michele De Lucchi, sinuoso ma allo stesso tempo ritmico, ottenuto attraverso la lavorazione della seduta fatta da un unico piano in legno ergonomico che continua in tutta la lunghezza della panca.

A bench made entirely in solid wood. The design is unmistakably that of Michele De Lucchi, sinuous and rhythmical, thanks to the way the seat is created out of a single plank of wood running along the complete length of the bench.

Eine vollständig aus Massivholz realisierte Bank. Unverkennbar das Design von Michele De Lucchi, gewunden aber gleichzeitig auch rhythmisch; die ergonomisch herausgearbeitete Sitzfläche wird aus einer einzigen Holzplatte angefertigt, die sich über die gesamte Banklänge erstreckt.

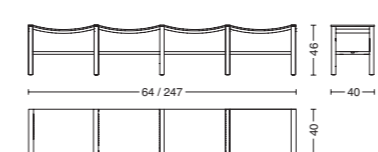

Cod. PIAZZA SCALA

H. 46  
 L. 64 - P. 40 (1 posto / 1 seat / 1 Platz)  
 L. 125,5 - P. 40 (2 posti / 2 seats / 2 Plätze)  
 L. 186,5 - P. 40 (3 posti / 3 seats / 3 Plätze)  
 L. 247 - P. 40 (4 posti / 4 seats / 4 Plätze)





## MOLLETTA - MOLLETTA MEDIUM - MOLLETTINA

Design: Baldessari e Baldessari

La panca Molletta, giocando con il tipico fuoriscalda dell'arte pop, regala al legno cedro un'interpretazione iper-naturale del materiale. L'oggetto si appropria in questo modo di una doppia vita: la prima è quella di un'ampia seduta pensata per grandi interni e per l'outdoor; la seconda è quella di potente elemento scultoreo, in grado di definire l'identità dello spazio circostante. La molletta ingigantita è però anche un omaggio al design semplice e anonimo che da sempre condivide silenziosamente la nostra quotidianità domestica. La lavorazione dei tagli obliqui esalta le venature e le sfumature del cedarwood naturale, creando quasi una texture virtuale che ricopre interamente l'oggetto. Disponibile in tre diverse dimensioni.

The Molletta bench uses a typical pop-art out-of-scale trick to give its cedar wood material a hypernatural effect. The bench therefore has a double life: firstly it is a wide seat designed for large indoor and outdoor spaces, and secondly it acts as a powerful sculptural element, which can define the identity of its context. The oversize Molletta (clothes peg) bench is also a tribute to the simple and anonymous design that silently shares our everyday life. Its slanted cuts highlight the grain and shades of the natural cedarwood, almost creating a virtual texture that covers the entire object. Available in 3 different sizes.

Die Bank Molletta erinnert an die Werke der Pop Art und schenkt dem Zedernholz eine sehr natürliche Material-Interpretation. Dieses Werk führt ein wahres Doppelleben: zunächst ist sie eine große Bank für geräumige Innenräume und Außenbereiche und als imposante Skulptur beeinflusst sie außerdem auch die Identität ihrer Umgebung. Die riesengroße Wäscheklammer will ferner an das einfache und anonyme Design des häuslichen Alltags erinnern. Die schrägen Schnitte betonen Maserung und Nuancen des natürlichen Zedernholzes und erzeugen fast eine virtuelle Beschaffenheit, die das gesamte Objekt umhüllt. In drei verschiedenen Größen erhältlich.

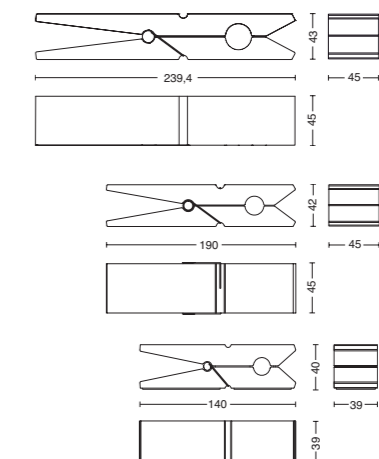

Cod. MOLLETTA  
L. 239,4 - P. 45 - H.43

Cod. MOLLETTA MEDIUM  
L. 190 - P. 45 - H.42

Cod. MOLLETTINA  
L. 140 - P. 39 - H.40

## CURVE BENCH

Design: Brodie Neill

Panca ricavata da un unico blocco di cedro massello e caratterizzata dalla forma arcuata al di sotto del piano di seduta che esalta le venature e le sfumature del cedarwood naturale. Disponibile anche con cuscinetto imbottito e rivestito in pelle.

The bench is cut out of a single block of cedar wood and features a sinuous, wavy form under the seat itself, highlighting the colour and grain of natural cedarwood. Also available with a small leather-covered cushion.

Diese Bank wird aus einem einzigen Zedernholzblock gefertigt, sie zeichnet sich durch einen Bogen unterhalb der Sitzfläche aus, der die Maserung und die natürlichen Nuancen vom Zedernholz betont. Auch mit einem Ledersitzkissen erhältlich.

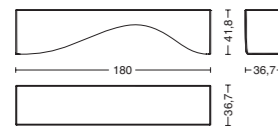

Cod. CURVE BENCH  
L. 180 - P. 36,7 - H. 41,8



# Mobili - Vettrine

## Chest of drawers - Cabinets Kommoden - Vitrine

- 92 **AKI**  
DESIGN: BARTOLI DESIGN
- 94 **KYOTO 2013**  
DESIGN: CR&S RIVA 1920
- 95 **KYOTO 4**  
DESIGN: CR&S RIVA 1920
- 96 **WABI**  
DESIGN: SETSU & SHINOBU ITO
- 97 **DAFNE**  
DESIGN: CR&S RIVA 1920
- 98 **RIALTO 2013**  
DESIGN: GIULIANO CAPPELLETTI
- 100 **RIALTO 2013 LOWBOARD**  
DESIGN: GIULIANO CAPPELLETTI
- 101 **RIALTO 2013 MODULO 4**  
DESIGN: GIULIANO CAPPELLETTI
- 102 **SOFT WOOD COMO**  
DESIGN: CARLO COLOMBO
- 102 **SOFT WOOD CREDENZA**  
DESIGN: CARLO COLOMBO
- 103 **ARABESQUE**  
DESIGN: LUCA SCACCHETTI
- 103 **LEVISTICO**  
DESIGN: RICCARDO ARBIZZONI
- 104 **RIALTO 2013 CABINET.3**  
DESIGN: GIULIANO CAPPELLETTI
- 106 **RIALTO 2013 CABINET.1**  
DESIGN: GIULIANO CAPPELLETTI
- 108 **COLONIA 2013**  
DESIGN: CR&S RIVA 1920
- 110 **CRU**  
DESIGN: CR&S RIVA 1920
- 112 **CAMBUSA WINE**  
DESIGN: GIULIANO CAPPELLETTI
- 114 **CAMBUSA COOK**  
DESIGN: GIULIANO CAPPELLETTI
- 116 **COLONIA 2012**  
DESIGN: CR&S RIVA 1920
- 117 **LIGHT SMALL**  
DESIGN: MATTEO THUN



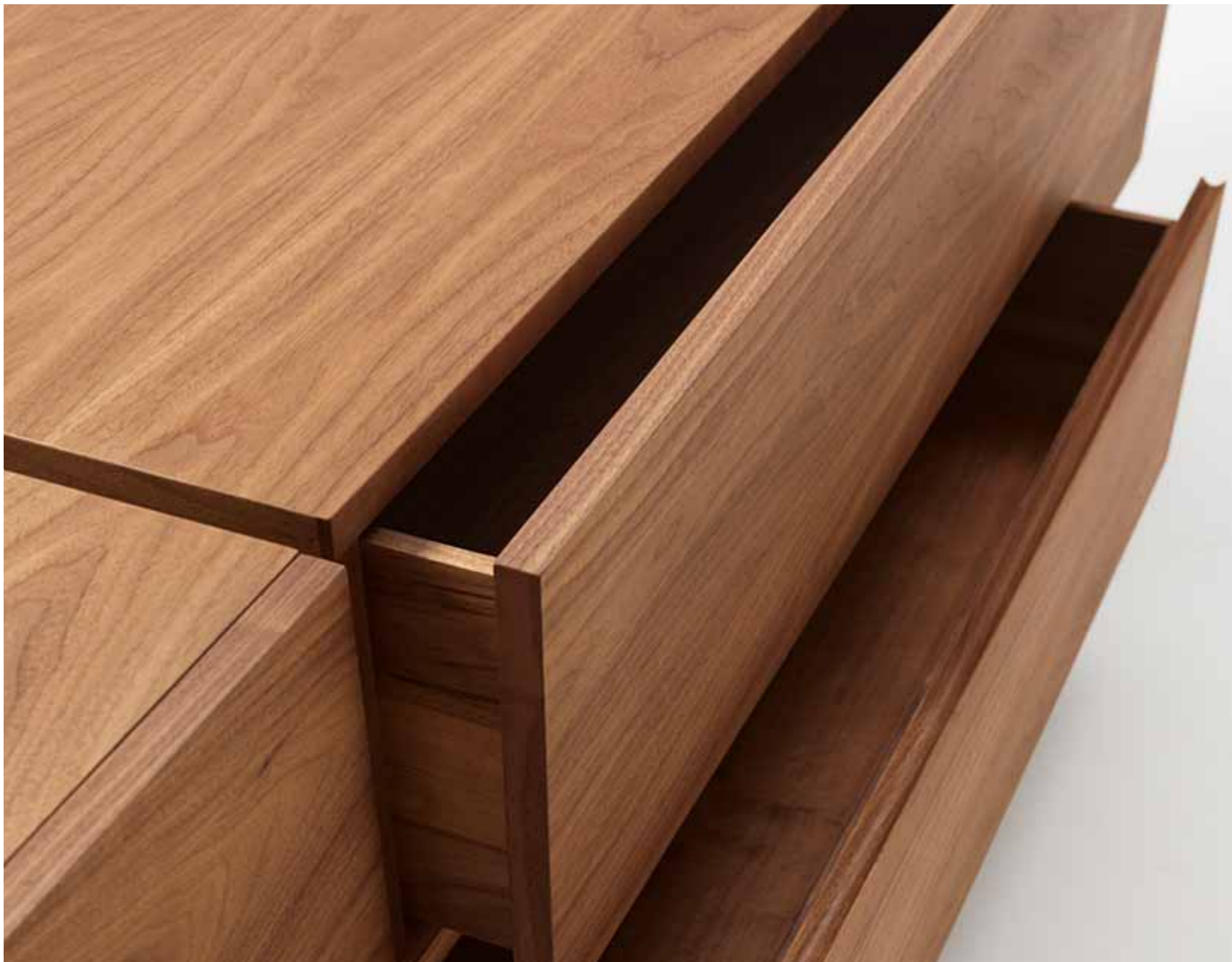

## AKI

Design: Bartoli Design

Mobile contenitore ad ante e cassetti nato dalla creatività dello Studio Bartoli Design, realizzato interamente in legno massello con struttura in multistrato impiallacciato noce. Il nome è molto espressivo: AKI, in giapponese è l'autunno, in riferimento al colore caldo del legno e alle linee pulite che caratterizzano la credenza dalla dinamica essenziale che esalta il pregio della materia prima.

Storage unit with doors and drawers demonstrate the creativity of Studio Bartoli Design: made completely out of solid wood with a frame in multilayer with walnut veneer. The name is very expressive: AKI is Japanese for autumn, referring to the warm colour of the wood and the clean lines of the dresser, whose fundamental movement brings out the beauty of the raw material.

Anrichte mit Schranktüren und Schubladen aus Massivholz und Struktur aus Vielschichtholz mit Nussbaum furniert. Der Name ist sehr ausdrucksvoll: AKI, auf Japanisch, bedeutet Herbst und bezieht sich auf die warme Farbe des Holzes und gleichzeitig auf die schlichte und essentielle Form der Anrichte.

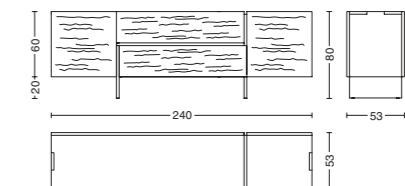

Cod. AKI  
L. 240 - P. 53 - H. 80

## KYOTO 2013

Design: CR&S Riva 1920

Credenza dalla linea semplice e squadrata, prevede una cassettiera centrale e due ante laterali, rialzata da terra grazie a un basamento centrale in legno massello. Il corpo del mobile è ottenuto attraverso una particolare lavorazione della sua sagoma che conferisce estrema leggerezza a tutto il mobile. Disponibile su misura e in tutte le essenze e finiture previste a catalogo.

A sideboard with simple, squared form, provided with a central section with drawers and two side doors. It is raised from the ground by a central base in solid wood. The body of the unit is created by a special way of working the profile to lend the item as a whole an extreme lightness. Available made-to-measure and with all the finishes offered by the Catalogue.

Die einfache und rechteckige Anrichte zeigt ein zentrales Schubladenelement und zwei seitliche Elemente mit Türen, mit einem zentralen Sockel aus Massivholz. Eine spezielle Bearbeitung der Formen verleiht diesem Möbel einen Anschein von Leichtigkeit. Erhältlich nach Maß und in allen vom Katalog vorgesehenen Holzarten und Ausführungen.

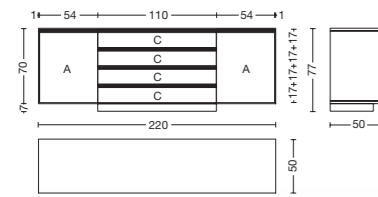

Cod. KYOTO 2013.1  
L. 220 - P. 50 - H. 77

## KYOTO 4

Design: CR&S Riva 1920

Contenitore a cassetti realizzato mantenendo la tradizione del cassetto assemblato con incastri a coda di rondine e arricchito dalla praticità dello scorrimento su binari metallici. Ogni cassetto è realizzato uno a uno, assemblato e testato dai nostri esperti falegnami. L'impugnatura per l'apertura dei cassetti è ottenuta grazie a una fresata sul frontale del cassetto. Disponibile anche su misura.

Chest of drawers made in the traditional way with dove-tail joints and aided by the practicality of sliding on metal runners. Each drawer is made separately, assembled and tested by our expert cabinet makers. The grips for opening the drawers are created by a groove on the front. Also available made-to-measure.

Anrichte mit Schubladen, die nach dem traditionellen Schwalbenschwanzprinzip zusammengebaut wurden und auf praktischen Metallschienen gleiten. Jede Schublade wird einzeln angefertigt und von unseren erfahrenen Tischlern zusammengebaut und getestet. Die Schubladen lassen sich durch eine gefräste Mulde öffnen, die an der Vorderseite ausgeführt wird. Auch als Maßanfertigung zu haben.

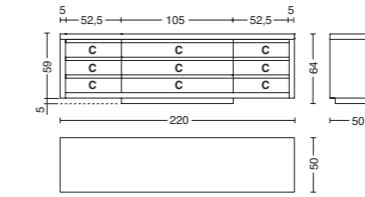

Cod. KYOTO 4  
L. 220 - P. 50 - H. 64





## WABI

Design: Setsu & Shinobu Ito

Credenza dei designer giapponesi Setsu & Shinobu Ito, dalle linee squadrate coniuga insieme legno e ferro in un mix di ante e cassetti. Il design è minimale dotato di grande stile ed eleganza, caratterizzato dalla presenza di un'anta con banda verticale in ferro che richiama uno dei cassetti con frontale in ferro.

Square-shaped sideboard designed by Japanese designer Setsu & Shinobu Ito, combining wood and iron in a mix of doors and drawers. Minimal design of great style and elegance, whose distinctive feature is a vertical iron strip echoing one of the drawers with an iron front.

Anrichte von japanischen Designer Setsu & Shinobu Ito, aus Holz und Eisen schafft er quadratische Formen und ein Mix aus Schubladen und Flügeltüren. Das Design ist minimalistisch und von großem Stil und Eleganz, eine Flügeltür weist einen vertikalen Eisenstreifen auf, der bei einer der Schubladen als Frontseite wiederholt wird.

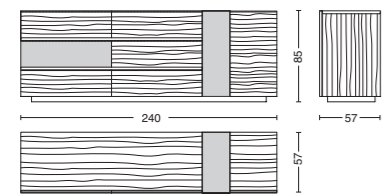

Cod. WABI  
L. 240 - P. 57 - H. 85

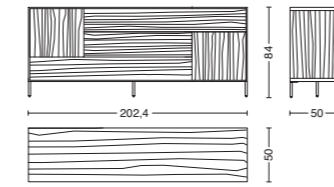

Cod. DAFNE 1  
L. 202,4 - P. 50 - H. 84

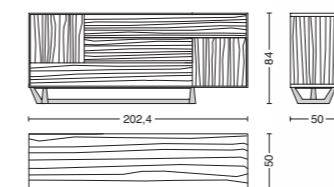

Cod. DAFNE  
L. 202,4 - P. 50 - H. 84



## DAFNE

Design: CR&S Riva 1920

Mobile costituito da cassetti ed ante realizzati con frontali e impiacchiatura del legno in senso orizzontale per i cassetti e verticale per le ante. Un abbinamento di grande effetto estetico che dona movimento e dinamicità al mobile.

A sideboard made up of drawers and doors with wooden fronts and veneers running horizontally for the drawers and vertically for the doors. A combination offering a powerful aesthetic effect and a sense of movement and dynamism.

Anrichte mit Schubladen und Türen, wobei das Holzfurnier bei den Schubladen in horizontaler und bei den Flügeltüren in vertikaler Richtung verläuft. Diese Kombination ist von großer ästhetischer Wirkung und verleiht dem Möbelstück Bewegung und Dynamik.



## RIALTO 2013

Design: Giuliano Cappelletti

Contenitore a sette cassetti dal design moderno e originale. I frontali dei cassetti, in legno massello e dotati di apertura push-pull, possono essere realizzati in varie tipologie di legno come noce, rovere o "briccola di Venezia". La struttura della cassetiera, invece, è disponibile in ferro colore naturale laccato trasparente, ferro laccato in vari colori, ferro effetto ossidato oppure, in alternativa, in legno nelle essenze noce o rovere.

Highboard with seven drawers with a modern and original design. The fronts of the drawers in solid wood have a push-pull opening mechanism; they can be made in various types of wood like walnut, or "Venetian Briccole" oak. On the contrary the frame is available in natural iron finished with a transparent lacquer, lacquered iron in different colours, in iron with rust effect, or alternatively in walnut or oak.

Hochkommode mit sieben Schubladen, modernes und originelles Design. Die Frontseiten der Schubladen sind aus Massivholz, Öffnungssystem push-pull. Die Frontseiten können auch aus verschiedenen Holzarten wie Nussbaum, Eiche oder „briccola di Venezia“ realisiert werden. Die Struktur der Hochkommode ist erhältlich in naturfarbenen, matt lackiertem Eisen, in lackiertem Eisen, in Eisen mit Oxydationseffekt oder, als Alternative, aus Nussbaum oder Eiche.

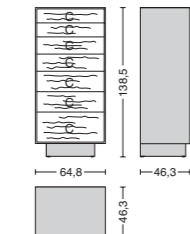

Cod. RIALTO 2013  
L. 64,8 - P. 46,3 - H. 138,5

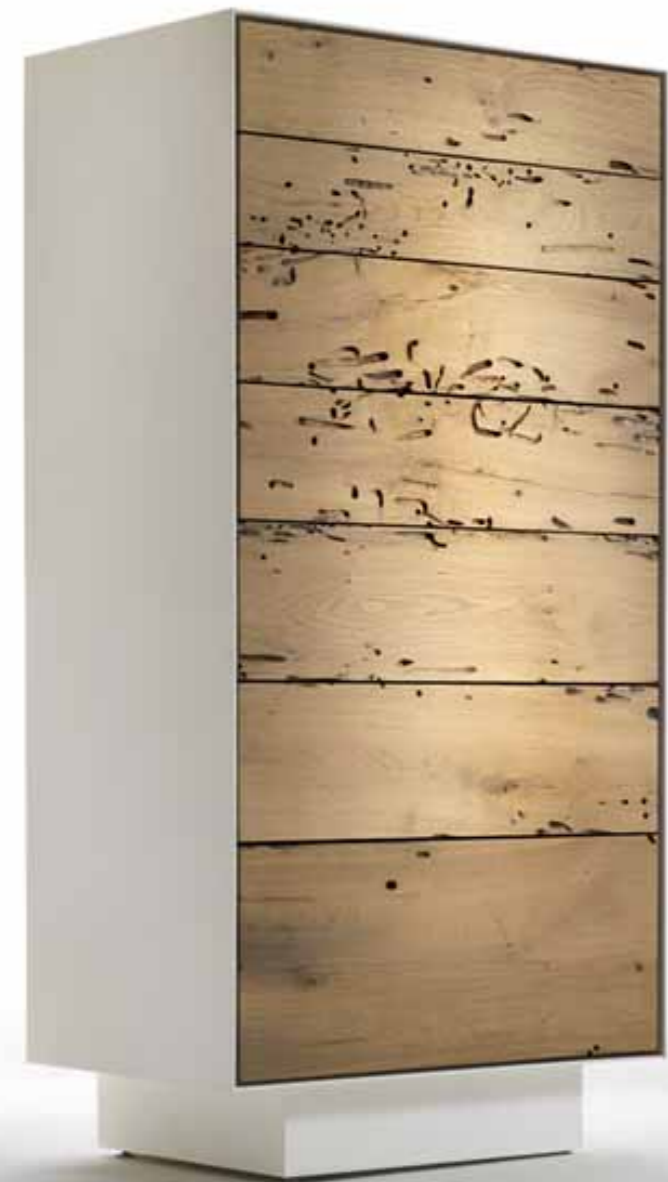

## RIALTO 2013 LOWBOARD

Design: Giuliano Cappelletti

Una versione "lowboard" della cassetiera Rialto. Seppur i tagli verticali sui frontali dei cassetti sembrano dare l'idea di un contenitore a nove cassetti, la cassetiera ospita invece sei cassetti in legno massello e dotati di apertura push-pull. Come per tutta la linea Rialto i cassetti possono essere realizzati in noce, rovere o rovere "briccola" mentre la struttura del mobile, è disponibile alternativamente in noce, rovere o in metallo nelle finiture e versioni previste a catalogo per la linea RIALTO.

A "lowboard" version of the Rialto chest of drawers. Although the vertical cuts on the frame of the drawers seem to give the impression of a chest with seven drawers, there are in fact six drawers in solid wood equipped with a push-pull opening mechanism. Like the rest of the Rialto collection, drawers can be in walnut, oak or "Venetian briccole" oak, while the structure is available either in walnut, oak or in metal with the range of finishes offered in our Catalogue for the RIALTO line.

Eine "Lowboard" Version der Kommode Rialto. Auch wenn die vertikalen Einschnitte auf der Schubladenvorderseite den Eindruck erwecken, die Kommode habe neun Schubladen, so sind doch tatsächlich sechs Schubladen aus massivem Holz mit push-pull Öffnungsmechanismus in ihr untergebracht. Wie bei der gesamten Produktlinie können die Schubladen aus Nussbaum, Eiche oder "Briccola" Eiche hergestellt werden, während die Struktur aus Nussbaum, Eiche oder Metall lieferbar ist, mit den Oberflächenfinishes und in den Versionen, die im Katalog für die Linie RIALTO vorgesehen sind.

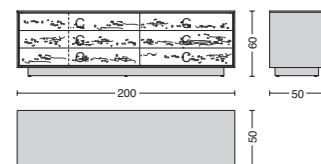

Cod. RIALTO LOW 2013  
L. 200 - P. 50 - H. 60



## RIALTO 2013 MODULO 4

Design: Giuliano Cappelletti

La serie *RIALTO MODULO* abbina invece nello stesso mobile vani con ante e con cassetti. Diversamente dalle serie con soli cassetti i modelli della serie *Rialto Modulo* sono realizzati con i frontali con liste di massello incollate in senso verticale. Come per tutta la linea Rialto anche questo modello può essere realizzato in noce, rovere o rovere "briccola" mentre la struttura del mobile, è disponibile alternativamente in noce, rovere o in metallo nelle finiture e versioni previste a catalogo per la linea RIALTO.

The *RIALTO MODULO* series combines in the same piece of furniture modules with doors and with drawers. As distinct from the series with only drawers the models in the *Rialto Modulo* series are made with a front of glued planks of solid wood arranged vertically. Like the rest of the Rialto line this model can be in walnut, oak or "Venetian briccole" oak, while the structure is available either in walnut, oak or in metal with the range of finishes offered in our Catalogue for the RIALTO line.

Die Serie *RIALTO MODULO* verbindet in einem Möbel Fächer mit Türen mit Schubladen. Die Modelle der Serie *Rialto Modulo* sind aus vertikal verleimten Massivholz realisiert. Dieses Modell kann auch aus Nussbaum, Eiche oder Eiche "Briccola" realisiert werden. Die Struktur hingegen ist aus Nussbaum, Eiche oder Metall in den vom Katalog für die Linie RIALTO vorgesehenen Ausführungen und Versionen erhältlich.

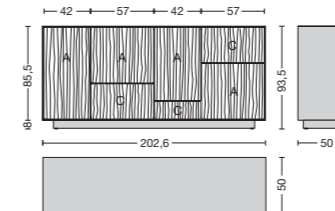

Cod. RIALTO MODULO 4.03  
L. 202,6 - P. 50 - H. 93,5





## SOFT WOOD COMÒ

Design: Carlo Colombo

Contenitori ad ante e cassetti in legno massello e multistrato. Dopo la realizzazione di letto, comodino, divano e poltrona, altri due pezzi si aggiungono alla raffinata collezione Softwood, disegnata dall'architetto Carlo Colombo. Le ultime nate sono la credenza e la cassetiera, mobili dalle linee pulite ed essenziali che si sposano perfettamente con un design moderno e all'avanguardia.

Sideboard in solid wood and multilayer. After designing the bed, the night-table, the sofa and the armchair, architect Carlo Colombo adds two more pieces to the elegant collection Softwood. The latest products are the sideboard and chest of drawers, which perfectly suit a modern design with its clean minimalist lines.

Anrichte aus Massiv- und Vielschichtholz. Nach dem Entwurf des Betts, des Nachttisches, des Sofas und des Sessels kommen jetzt zwei neue Produkte zur raffinierten Softwood Kollektion hinzu, die vom Architekten Carlo Colombo entworfen wurde: Anrichte und Kommode. Beide haben saubere und essentielle Linien, die perfekt zu einem modernen und zeitgenössischen Design passen.

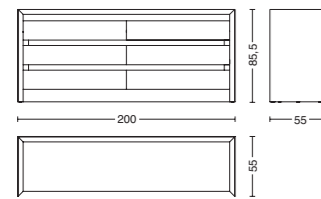

Cod. **SOFTWOOD 2**  
L. 200 - P. 55 - H. 85,5



## SOFT WOOD CREDENZA

Design: Carlo Colombo

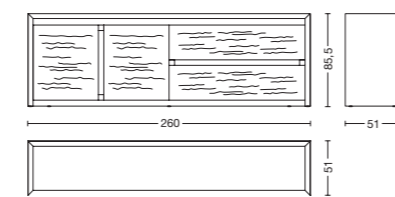

Cod. **SOFTWOOD 1**  
L. 260 - P. 51 - H. 85,5

## ARABESQUE

Design: Luca Scacchetti



Contenitore firmato Luca Scacchetti e realizzato in legno multistrato. Arabesque è un mobile a quattro ante costituito da quattro vani e dotato di un ripiano per vano. L'apertura delle ante è con sistema push-pull per mantenere la massima linearità della composizione. Disponibile anche su misura e in diverse essenze.

Sideboard designed by Luca Scacchetti and made of multilayer. Arabesque is a piece of furniture with four doors and consisting of four modules each provided with a shelf. Also available custom-made and in different wood types.

Anrichte aus Vielschichtholz, Designer Luca Scacchetti. Arabesque ist ein Möbelstück mit vier Holztüren und eben soviel Fächern, mit einem Einlegeboden pro Fach. Das Öffnen der Türen erfolgt nach dem Push-Pull System, um die Linearität nicht zu stören. Auch als Maßanfertigung und aus anderen Hölzern erhältlich.

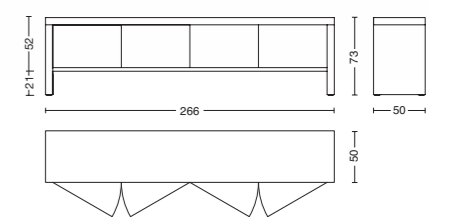

Cod. **ARABESQUE-SIDE**

H. 73 cm.  
L. 107 - P. 50  
L. 147 - P. 50  
L. 200 - P. 50  
L. 266 - P. 50



## LEVISTICO

Design: Riccardo Arbizioni

Contenitore dalle linee pulite ed essenziali firmato Riccardo Arbizioni e realizzato in legno multistrato. Levistico è un mobile a quattro ante con apertura speculare, dotato di un ripiano per vano e di un cassetto interno nella parte centrale del mobile. Disponibile anche su misura e in diverse essenze.

Sideboard with a clean and compact shape, designed by Riccardo Arbizioni and made of multilayer wood. Levistico is a piece of furniture with four doors with symmetrical opening, equipped with a shelf in each module and an internal drawer in the central part of the cabinet. Available also custom-made and in different wood types.

Anrichte mit sauberen und essentiellen Linien aus Multischichtholz, Designer Riccardo Arbizioni. Levistico ist ein Möbelstück mit vier Flügeltüren und symmetrischer Öffnung, hat einen Einlegeboden pro Fach und eine Schublade im zentralen Teil. Auch als Maßanfertigung und aus anderen Hölzern erhältlich.

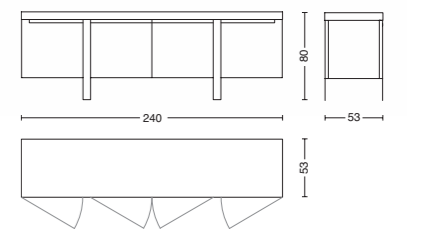

Cod. **LEVISTICO**

L. 240 - P. 53 - H. 80



## RIALTO 2013 CABINET.3

Design: Giuliano Cappelletti

Dopo il successo delle cassettiere RIALTO il designer Giuliano Cappelletti propone per Riva una serie di vetrine che confermano gli abbinamenti di materiali diversi ma ugualmente "puri" come il legno, il metallo e il vetro. La struttura esterna della vetrina può essere in lamiera di metallo spessore 3 mm realizzata in ferro laccato trasparente o colorato. Le ante sono realizzate con una cornice in legno multistrato impiallacciato e cristallo trasparente. L'allestimento interno è completato da ripiani regolabili in altezza. Disponibile anche nella versione con struttura esterna completamente in legno.

Following the success of his RIALTO chest of drawers, designer Giuliano Cappelletti for Riva offers a series of display units which combine different but equally "pure" materials: wood, metal and glass. The external structure of the unit can be in 3 mm-thick iron with a transparent or coloured lacquered finish. The doors are made of clear glass with a frame in veneered multilayer. The internal arrangement has height-adjustable shelves. Also available in a version with the external structure entirely in wood.

Nach dem Erfolg mit den RIALTO Kommoden schlägt der Designer Giuliano Cappelletti Riva eine Vitrinenserie vor, die eine Bestätigung der Materialkombination ist. Es werden unterschiedliche aber trotzdem "reine" Werkstoffe wie Holz, Metall und Glas kombiniert. Die Außenstruktur der Vitrine kann aus 3 mm dickem und transparent oder farbig lackiertem Metallblech hergestellt werden. Die Flügeltüren haben einen Rahmen aus furniertem Multischichtholz und darin transparentes Glas. Die Innenausstattung wird durch höhenverstellbare Einlegeböden vervollständigt. Auch in der Version mit Außenstruktur vollständig aus Holz erhältlich.

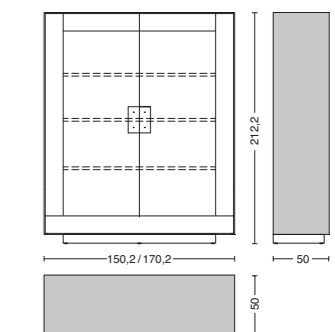
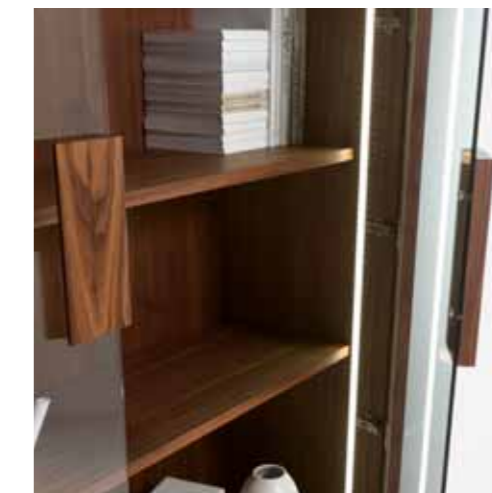

Cod. RIALTO CAB.3

H. 212 cm.  
L. 150,2 - P. 50  
L. 170,2 - P. 50



## RIALTO 2013 CABINET.1

Design: Giuliano Cappelletti

Vetrina con struttura in legno listellare impiallacciato e legno massello. Struttura esterna in lamiera di metallo spessore 3 mm realizzata in ferro laccato trasparente o colorato. Nella parte superiore si trovano due ante con cornice in legno e cristallo trasparente. Interno completato da ripiani regolabili in altezza. La parte inferiore è completata da tre cassetti con apertura "push-pull". Disponibile anche nella versione con struttura esterna in legno e nelle dimensioni previste a catalogo.

Display unit with structure in multilayer veneered and solid wood. External structure in 3 mm-thick sheet metal, iron with a transparent or coloured lacquered finish. The upper part has two doors of clear glass with a wooden frame. The internal arrangement has height-adjustable shelves. The lower part has three drawers with a "push-pull" opening mechanism. Also available in a version with the external structure entirely in wood and in the dimensions given in the Catalogue.

Vitrine mit Struktur aus furnierter Multischichtholz und Massivholz. Die Außenstruktur wird aus 3 mm dickem und transparent oder farbig lackiertem Metallblech hergestellt. Im oberen Teil befinden sich zwei Flügeltüren mit Holzrahmen und transparentem Glas. Die Innenausstattung wird durch höhenverstellbare Einlegeböden vervollständigt. Der untere Teil weist drei Schubladen mit "Push-Pull" Öffnungssystem auf. Auch in der Version mit Außenstruktur aus Holz erhältlich, in den Maßen gemäß Katalog.

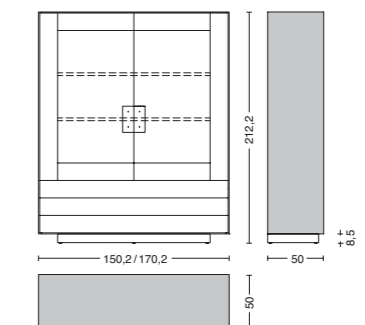

Cod. RIALTO CAB.1  
H. 212 cm.  
L. 150,2 - P. 50  
L. 170,2 - P. 50





## COLONIA 2013

Design: CR&S Riva 1920

La serie Colonia 2013 è caratterizzata da un restyling delle precedenti versioni minimizzando, solo visivamente, gli spessori della struttura rendendo il mobile più moderno senza tuttavia tralasciare le qualità di un mobile ancora realizzato e costruito a mano. Struttura in legno liscellare impiallacciato e massello. Ante in cristallo trasparente con cornice in legno massello sulla quale è ricavata anche la maniglia. All'interno delle due ante così come nella parte inferiore della vetrina si trovano due cassetti con apertura push pull. Disponibile nelle varie essenze e dimensioni indicate a catalogo.

The Colonia 2013 series is distinguished by a restyling of the previous versions, minimising in visual terms the thicknesses of the structure and making the piece more modern without any reduction in quality. It is still handmade. The structure is in veneered multilayer and solid wood. The doors are in clear glass with solid wood frames moulded to create a handle. Inside the two doors – and similarly in the lower part of the display unit – there are two drawers with a push-pull opening mechanism. Available in the various types of wood and dimensions indicated in the Catalogue.

Die Serie Colonia 2013 zeichnet sich durch ein Restyling der Vorgängerversionen aus, wobei die Wandstärke der Struktur optisch minimiert wurde, was dem Möbelstück einen moderneren Touch verleiht ohne auf die Qualität eines von Hand gefertigten Produktes zu verzichten. Struktur aus furnierter Multischichtplatte und Massivholz. Flügeltür aus transparentem Glas mit Rahmen aus Massivholz, in den auch der Griff eingearbeitet wurde. Im Vitrineneinneren sowie im unteren Teil befinden sich zwei Schubladen mit Push Pull Öffnungssystem. Erhältlich in den im Katalog angegebenen Hölzern und Maßen.

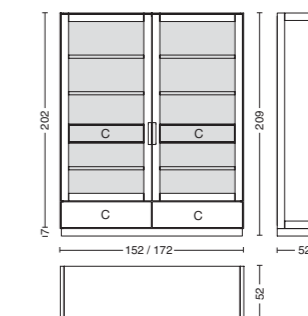

Cod. 2.27.18  
H. 209 cm.  
L. 152 - P. 52  
L. 172 - P. 52



## CRU

Design: CR&S Riva 1920

Contenitore in legno e "cantina" per bottiglie di vino o birra. CRU viene proposta con accessori in legno e metallo al fine di poter soddisfare le esigenze del cliente: ripiani interni in legno orizzontale con diagonale in ferro (singola o doppia) oppure con griglia contenitiva in legno per bottiglie o cassettiere che prevedono un modulo d'appoggio per bicchieri. CRU è adattabile e versatile sulla base delle diverse necessità sia per usi privati sia per locali pubblici come ristoranti, bar o vinoteche.

Wooden highboard and wine or beer cabinet. CRU comes with accessories in both wood and metal to meet the customer's needs: internal horizontal shelves in wood with iron diagonals (single or double) or with a wooden grid for bottles or a set of drawers with a shelf for glasses. CRU is very versatile, being easily adaptable to a range of both private needs and public places, like restaurants, pubs or wine bars.

Holzbehälter und "Weinkeller" für Wein- oder Bierflaschen. CRU wird mit Zubehörteilen aus Holz und Metall angeboten um allen Ansprüchen des Kunden gerecht zu werden: horizontale Einlegeböden aus Holz mit Diagonalen aus Eisen (einfach oder doppelt) oder mit Holzraster für Flaschen oder Schubladenbereiche mit Glasabstellmodul. CRU ist anpassungsfähig und kann je nach Bedarf in privaten oder gewerblich genutzten Räumlichkeiten zur Anwendung kommen wie z.B. in Restaurants, Bars oder Weinkellern.

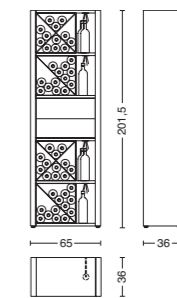

Cod. CRU COMPOS. 2  
L. 65 - P. 36 - H. 201,5

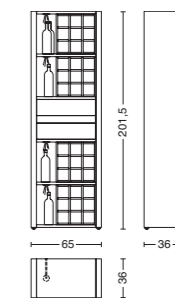

Cod. CRU COMPOS. 1  
L. 65 - P. 36 - H. 201,5



**IMPORTANTE:** per una maggiore stabilità e sicurezza, prima di montare le ante dei mobili della serie CAMBUSA è necessario fissare il corpo del mobile al muro.

**ATTENTION:** for a better safety and stability, before assembling the doors of CAMBUSA cabinets, it is recommended to fix the cabinet to the wall.

**WICHTIG:** für eine bessere Sicherheit und Stabilität, bevor der Zusammenstellung der Türen von CAMBUSA Anrichten, ist eine Befestigung der Möbel an der Wand notwendig.

## CAMBUSA WINE

Design: Giuliano Cappelletti

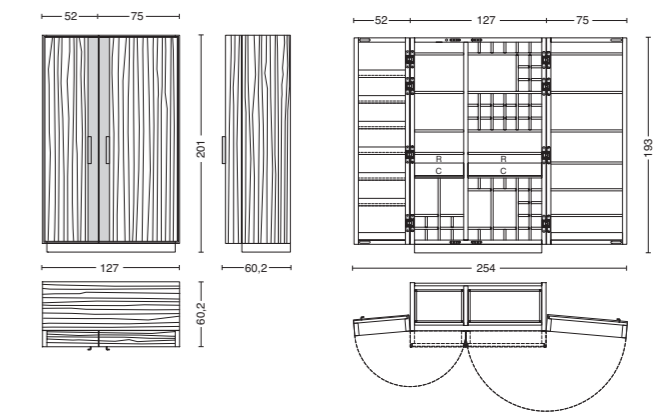

Cod. CAMBUSA WINE  
L. 127/254 - P. 60,2 - H. 201



Mobile contenitore multifunzione, versatile grazie alle numerose possibilità di utilizzo in numerosi contesti come cucina, sala da pranzo, mobile ufficio direzionale, ristoranti, enoteche ecc. L'attrezzatura e i complementi interni sono pensati sulla base della loro finalità d'uso e funzione che può essere anche personalizzata in relazione alle singole esigenze di ogni cliente. Ecco che piccoli elettrodomestici, di solito presenti in un ambiente cucina, come la macchina del caffè, il forno a microonde, tazze, bicchieri, stoviglie, così come tutto l'occorrente per gli amatori del vino o della birra si inseriscono con praticità in ambienti non convenzionali grazie all'eleganza dei mobili Cambusa. Le grandi ante sono la caratteristica principale di questo mobile: la loro struttura consente di sistemare bicchieri e oggetti di vari formati. I vani interni del mobile sono inoltre illuminati grazie a un sistema di luci a LED posizionate su tutta l'altezza della spalla interna. La loro accensione risulta automatica grazie a sensori che all'apertura dell'anta attivano i LED. Il mobile cambusa, qui presentato in legno noce, è disponibile anche in rovere e in tutte le essenze previste dalla Collezione R1920.

A multifunctional storage unit: it offers several options depending on the context: kitchen, dining room, manager's office, restaurant, wine bar etc.

The equipment and the internal accessories have been selected and designed according to their function and can be customized to meet each individual client's needs. See how small domestic appliances usually present in a kitchen area, like a coffee machine, microwave oven, cups, glasses, dishes, and all that the wine or beer lover requires can be housed in a practical way in unconventional contexts, thanks to the elegance of the Cambusa line. The big doors are stand-out feature of this piece of furniture: they are manufactured so as to allow glasses and objects of various sizes and shapes to be stored. In addition, the internal spaces are lit by a system of LED lights positioned along the whole height of the internal side panel. These lights come on automatically thanks to sensors which activate the LEDs when the door is opened. Cambusa, pictured here in walnut, is also available in oak and in all the types of wood in the R1920 Collection.

Ein geräumiges Multifunktionsmöbelstück, das dank der zahlreichen Nutzungsmöglichkeiten in unterschiedlichsten Kontexten zur Anwendung kommen kann wie z.B. in der Küche, im Esszimmer, im Büro des Direktors, im Restaurant, in Weinkellern etc.

Die Innenausstattung wurde auf Grundlage von Anwendungszweck und Zweckmäßigkeit geplant und kann je nach Bedarf des einzelnen Kunden auch individuell ausgeführt werden. Auch kleine Haushaltsgeräte, die sonst in einer Küche zu finden sind, wie z.B. Kaffeemaschine, Mikrowellenherd, Tassen, Gläser, Geschirr sowie all das, was Wein- oder Bierliebhaber benötigen, lassen sich problemlos in einem ganz unkonventionellen Ambiente unterbringen, dank der Eleganz der Möbelstücke Cambusa. Die großen Flügeltüren sind das Hauptmerkmal dieses Möbelstücks: ihre Struktur ermöglicht die Unterbringung von Gläsern und Gegenständen unterschiedlichster Formate. Die diversen Schrankinnenräume werden dank eines LED Systems beleuchtet, das längs der gesamten Höhe der internen Zwischenwand angebracht ist. Sein Einschalten erfolgt automatisch durch Sensoren, die beim Öffnen der Schranktür die LEDs aktivieren. Das hier in Nussbaum vorgestellte Möbelstück Cambusa ist auch aus Eichenholz erhältlich und in allen Holzsorten aus der Kollektion R1920.

**IMPORTANTE:** per una maggiore stabilità e sicurezza, prima di montare le ante dei mobili della serie CAMBUSA è necessario fissare il corpo del mobile al muro.

**ATTENTION:** for a better safety and stability, before assembling the doors of CAMBUSA cabinets, it is recommended to fix the cabinet to the wall.

**WICHTIG:** für eine bessere Sicherheit und Stabilität, bevor der Zusammenstellung der Türen von CAMBUSA Anrichten, ist eine Befestigung der Möbel an der Wand notwendig.

## CAMBUSA COOK

Design: Giuliano Cappelletti

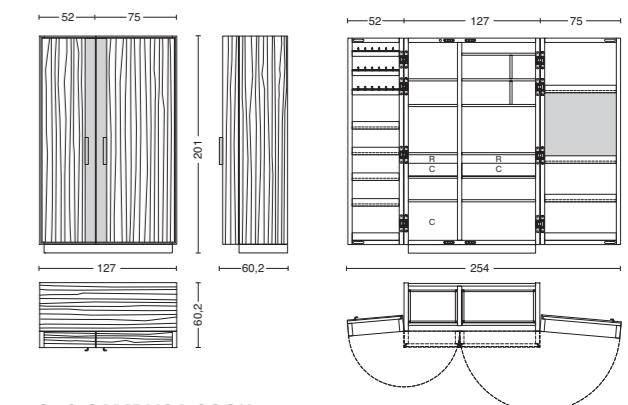

Cod. CAMBUSA COOK  
L. 127/254 - P. 60,2 - H. 201



Cod. 2.27.17  
L. 200 - P. 53,2 - H. 212,7

## COLONIA 2012

Design: CR&S Riva 1920

La credenza Colonia 2012 presenta una struttura in legno massello, schienali in multistrato impiallacciato e ripiani in legno regolabili in altezza. Ante in cristallo temperato. I due vani sono separati da una colonna centrale costituita da tre piccoli vani e, nella parte inferiore, cinque cassetti scorrevoli su binari metallici con chiusura ammortizzata. Vetrina disponibile in tutte le essenze e finiture previste dalla Collezione Riva 1920 e realizzabile anche su misura.

Colonia 2012 has a solid wood structure, back panels made of veneered multilayer, and height-adjustable shelves. Doors in tempered glass. The two compartments are separated by a central column made up of three small spaces and, at the bottom, five drawers running on metal rails with soft closure. Cabinet available in all kinds of wood and finishes provided by Riva Collection. Also available custom-made.

Die Anrichte Colonia 2012 hat eine Struktur aus Massivholz, Rückwände aus furniertem Multischichtholz und höhenverstellbare Einlegeböden aus Holz. Flügeltüren aus gehärtetem Glas. Die beiden Innenräume werden durch eine zentrale Säule getrennt, die ihrerseits aus drei kleinen Fächern und, im unteren Teil, aus fünf Schubladen besteht, die auf Metallschienen gleiten und gedämpft schließen. Diese Vitrine ist in allen Hölzern und Oberflächenfinishes unserer Kollektion und auch als Maßanfertigung erhältlich.

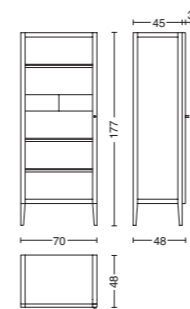
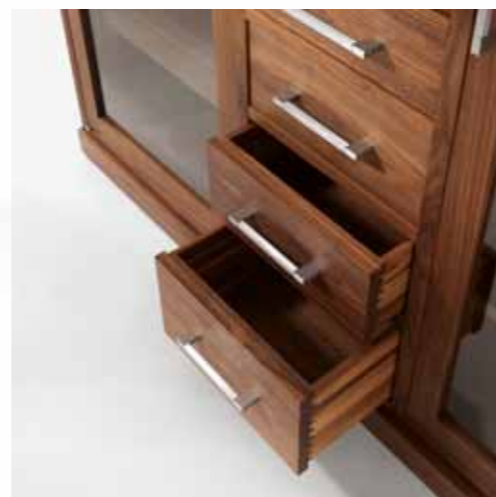

Cod. LIGHT SMALL  
L. 70 - P. 48 - H. 177



## LIGHT SMALL

Design: Matteo Thun

Disegnata da Matteo Thun, la vetrina LIGHT SMALL integra la gamma dell'omonima serie che comprende già il tavolo, la panca e la vetrina Light. Caratteristica che accomuna la serie LIGHT di Matteo Thun sono gli spessori dei piani e delle strutture otticamente ridotti, senza rinunciare alla solidità di un prodotto in legno massello. L'anta è realizzata in cristallo trasparente racchiusa da una fine cornice in legno massello. All'interno il vano unico consente di essere sfruttato al meglio anche grazie a due piccoli cassettini portaoggetti e tre ripiani in legno.

Designed by Matteo Thun, the LIGHT SMALL display unit is part of the range of the same name that already includes a table, the bench and the Light display unit. The common characteristics of Matteo Thun's LIGHT series are the thin shelves and structural elements, which notwithstanding have the same stability of a product in solid wood. The door is made of clear glass with a solid wood frame. The single interior space allows optimal use, also thanks to the two small drawers and three wooden shelves.

Die Vitrine LIGHT SMALL wurde von Matteo Thun entworfen und ergänzt die gleichnamige Serie, die bereits Tisch, Bank und die Vitrine Light umfasst. Das, was die gesamte Serie LIGHT von Matteo Thun gemein hat, sind die optisch reduzierten Wandstärken der Einlegeböden und Strukturen, ohne auf die Solidität eines Massivholzproduktes zu verzichten. Die Flügeltür besteht aus transparentem Glas und wird von einem feinen Massivholzrahmen umschlossen. Der Innenraum wurde für eine bestmögliche Nutzung des Platzes mit zwei kleinen Schubladen und drei Einlegeböden aus Holz versehen.

# Librerie

## Bookshelves

### Regalsysteme

- 120 **LIBRERIA BRIE**  
DESIGN: MARC SADLER
- 122 **CRAZY**  
DESIGN: CR&S RIVA 1920
- 124 **FREEDOM**  
DESIGN: NATURA COLLECTION BY RIVA
- 128 **PASSWORD**  
DESIGN: CR&S RIVA 1920
- 130 **BOOKSHELF**  
DESIGN: DAVID CHIPPERFIELD
- 132 **TUBULAR**  
DESIGN: JAMIE DURIE
- 134 **RIALTO 2013 WALL UNIT**  
DESIGN: GIULIANO CAPPELLETTI
- 136 **TORRE LIGNEA**  
DESIGN: MICHELE DE LUCCHI
- 138 **VAMIZI SMALL**  
DESIGN: TERRY DWAN
- 139 **VAMIZI TV WALL**  
DESIGN: TERRY DWAN





## BRIE

Design: Marc Sadler

Originale libreria realizzata con ripiani in legno massello di noce nella quale viene evidenziata la bellezza del legno massello grazie ai ripiani presentati con i bordi naturali che ne esaltano il colore e le caratteristiche. Gli elementi verticali che costituiscono la struttura della libreria Brie sono realizzati in lamiera di ferro color naturale laccato trasparente o, a richiesta, in ferro laccato nei colori previsti dalla scala RAL. Disponibile in diverse dimensioni e anche su misura.

An original bookshelf with solid walnut shelves that show off the beauty of natural wood thanks to its natural sides, bringing out its colour and organic form. The vertical elements that make up the structure of the Brie bookcase are made of iron with a natural colour and transparent lacquered finish or, if requested, iron lacquered in the RAL range of colours. Available in various dimensions or made-to-measure.

Originelles Bücherregal mit Fachböden aus massivem Nussbaumholz. Die Schönheit des Massivholzes wird dadurch hervorgehoben, dass die Ränder naturbelassen wurden, was Farbe und Merkmale unterstreicht. Die vertikalen Elemente, aus denen die Struktur des Bücherregals Brie besteht, werden aus transparent lackiertem Roheisenblech gefertigt, oder auf Anfrage aus farbig lackiertem Eisenblech mit RAL Farbe. In diversen Größen und auch als Maßanfertigung erhältlich.

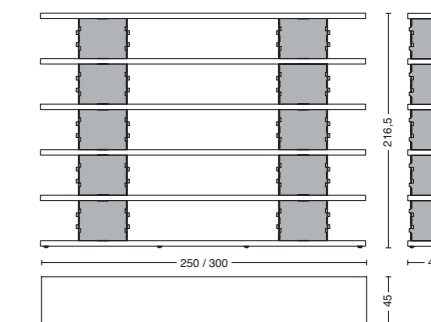

Cod. BRIE-COMP2  
L. 250/300 - P. 45 - H. 216,5



## CRAZY

Design: CR&S Riva 1920

Libreria dalle linee minimali, costituita da una cornice in ferro sabbato laccato trasparente o con colori a scelta, e mensole in legno massello con nodi che si intersecano e fuoriescono dalla struttura esterna. Elemento caratterizzante della libreria risulta essere l'unicità del bordo esterno delle mensole proposto nella forma naturale del legno. La struttura della libreria Crazy, in relazione alla dimensione richiesta, deve essere fissata a muro e per alcune misure è richiesto anche il fissaggio di ogni singolo ripiano.

A bookcase with minimalist lines, made up of a brushed iron frame with a transparent or coloured finish as requested and solid wood shelves with knots which cross over and protrude from the outer structure. The dominant feature of the bookcase is the unity of the outer border of the shelves, following the natural shape of the wood. Depending on the dimensions requested, the structure of the bookcase must be fixed to the wall and in some cases even fixed shelf by shelf.

Bücherregal mit minimalistischen Linien, besteht aus einem sandbestrahlten und transparent oder farbig lackiertem Eisenrahmen und Fachböden aus massivem Holz mit Knoten, die sich mit der Außenstruktur überlappen und daraus hervortreten. Ein kennzeichnendes Element für dies Bücherregal ist der einzigartige Außenrand der Fachböden, der in der natürlichen Form des Holzes angeboten wird. Je nach gewünschter Größe wird die Struktur des Bücherregals Crazy an der Wand festgemacht und bei einigen Größen ist auch die Festmachung jedes einzelnen Fachbodens erforderlich.

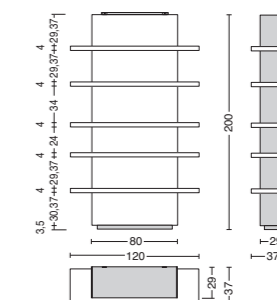

Cod. CRAZY

H. 200 cm.  
L. 120 - P. 37  
L. 160 - P. 37  
L. 180 - P. 37  
L. 200 - P. 37  
L. 220 - P. 37  
L. 240 - P. 37  
L. 280 - P. 37



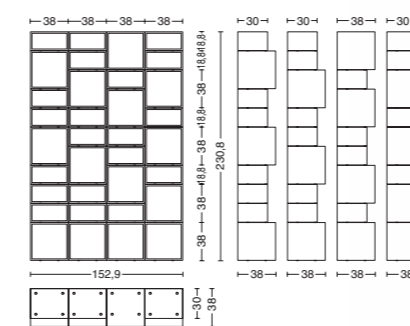

Cod. FREEDOM PROJECT 4  
L. 152,9 - P. 30/38 - H. 230,8

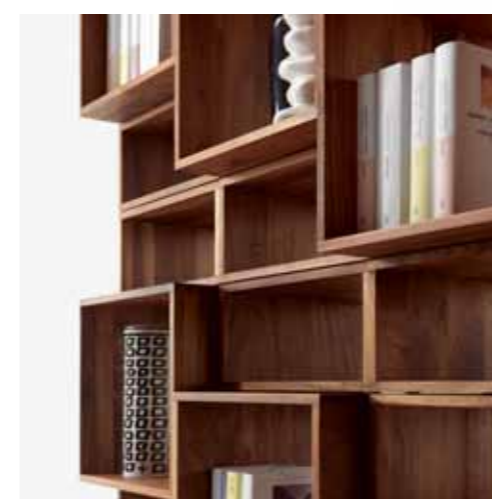

## FREEDOM

Design: Natura Collection by RIVA

FREEDOM un nuovo modo di comporre in libertà la propria libreria ideale. FREEDOM è infatti composta da moduli indipendenti in legno massello di misure cm. L. 38 x P. 38 x H. 38 e da moduli cm. L. 38 x. P. 30 x H. 18,8, impilabili e accostabili tra loro attraverso specifica ferramenta di montaggio. Dal carattere flessibile sulla base delle esigenze di arredo con possibilità di inserimento di ante, cassetti e vano tv. FREEDOM è disponibile in tutte le essenze previste dalla Collezione RIVA 1920. Per le modalità di realizzazione delle composizioni, eventuali integrazioni e relative limitazioni, consultare le indicazioni specifiche sul Listino Prezzi.

FREEDOM offers a new way of freely composing your own ideal bookcase. FREEDOM is in fact made up of independent modules in solid wood measuring l. 38 x d. 38 x h. 38 cm and of others measuring l. 38 x. d. 30 x h. 18.8 cm, that can be stackable and placed side-by-side using a special metal locking piece. It demonstrates its flexibility in adapting to different needs and by its ability to be fitted with doors, drawers and a TV compartment. FREEDOM is available in all the types of wood in the RIVA 1920 Collection. For more information regarding the way units can be composed, any additions and related limitations, please consult the relative notes in the Price List.

FREEDOM ist eine neue Art sich sein Wunschbücherregal selbst zusammenzustellen. In der Tat besteht FREEDOM aus unabhängigen Massivholzmodulen mit den Maßen B. 38 x T. 38 x H. 38 cm und B. 38 x T. 30 x H. 18,8 cm, die mit Hilfe spezieller Montagebeschläge untereinander stapel- und positionierbar sind. FREEDOM ist flexibel und kann je nach Bedarf mit Flügeltüren, Schubladen und TV Fächern versehen werden. Das Modell ist aus allen Hölzern erhältlich, die in der Kollektion RIVA 1920 vorgesehen sind. Was die Zusammenstellung, eventuelle Ergänzungen und Einschränkungen betrifft, bitte die relativen Angaben auf der Preisliste beachten.



**FREEDOM TV**  
Design: Natura Collection by RIVA

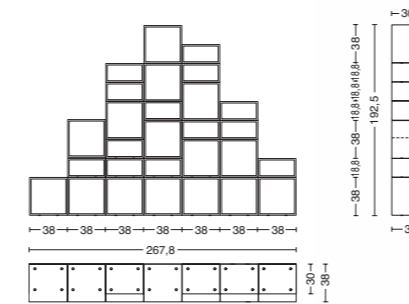

Cod. FREEDOM PROJECT 5  
L. 267,8 - P. 30/38 - H. 192,5



**FREEDOM**  
Design: Natura Collection by RIVA

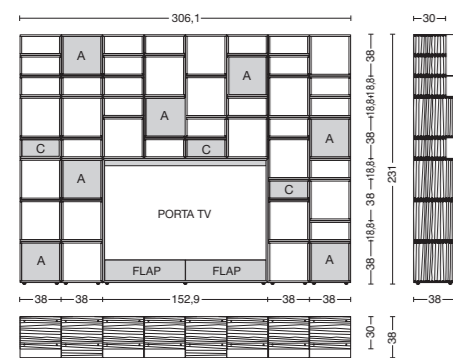

Cod. FREEDOM PROJECT TV  
L. 306,1 - P. 30/38 - H. 231

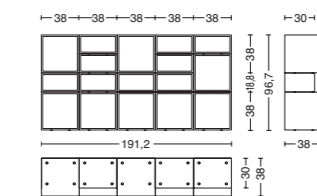

Cod. FREEDOM PROJECT 2  
L. 191,2 - P. 30/38 - H. 96,7



## PASSWORD

Design: CR&S Riva 1920

Una libreria dal design semplice, caratterizzata dall'asimmetria di alcune spalle divisorie intermedie. E' un sistema componibile fatto da spalle e ripiani in multistrato impiallacciato. Per personalizzare la propria versione di libreria sono inoltre disponibili vari elementi tra cui cassetti ed ante che possono avere frontali in legno oppure rivestiti con finiture effetto cemento, in ferro laccato, o in vetro. La libreria Password è inoltre disponibile anche con elementi "bifacciali".

A bookcase with a simple design, yet highly individual thanks to the asymmetry of some of the intermediate upright dividers. It is a modular system made up of uprights and shelves in veneered multilayer. The bookcase can be given a personal touch by choosing from a range of elements including drawers and doors with surfaces in wood or concrete effect, in lacquered iron or glass. The Password bookcase is also available with units having both front and back.

Ein Bücherregal mit einem schlichten Design, das sich durch die Asymmetrie einiger Zwischentrennwände auszeichnet. Das System ist zusammenstellbar und besteht aus Zwischenwänden und Fachböden aus furniertem Mehrschichtholz. Um die eigene Bücherregalversion individuell gestalten zu können, stehen diverse Elemente zur Verfügung wie z.B. Schubladen und Flügeltüren, deren Vorderseite aus Holz oder mit einem Zementeffekt-Oberflächenfinish, sowie aus lackiertem Eisen oder Glas ausgeführt werden kann. Das Password Bücherregal ist außerdem mit Duplex Elementen erhältlich.

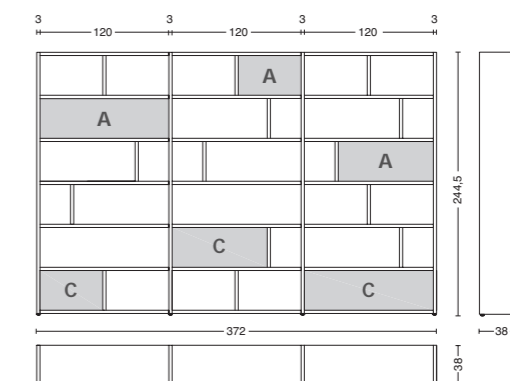

Cod. PASSWORD PROJECT 1  
 L. 372 - P. 38 - H. 244,5

A Modulo con anta a ribalta  
 Flap door element  
 Modul mit klappe

C Modulo con cassetto  
 Drawer element  
 Modul mit schublade



## BOOKSHELF

Design: David Chipperfield

*"Nella realizzazione fisica di un prodotto di design la sfida è quella di dare valore al materiale come alla forma".*  
 Queste sono le parole di David Chipperfield usate per descrivere la sua BOOKSHELF.

Pensata per essere originariamente realizzata in legno rovere "bricole" di Venezia, ora viene proposta in tutte le essenze previste dalla Collezione R1920. Libreria completamente in legno massello adatta per la sistemazione di libri e documenti. Il piano sporgente rispetto agli altri ripiani della libreria è un ottimo aiuto per appoggiare gli oggetti o i documenti che si stanno utilizzando o come pratico piano scrittoio. La libreria è disponibile in diverse dimensioni e a richiesta anche su misura.

*"In the physical construction of a design product, the challenge is to bring out the value of the material as much as the form".*  
 These are the words used by David Chipperfield to describe his BOOKSHELF.

Originally designed to be made of oak from recycled Venetian "bricole", the bookcase is now offered in all the types of wood in the R1920 Collection. The bookcase is made completely of solid wood and is ideal for holding books and documents. The surface protruding beyond the other shelves is an excellent aid by providing a place to rest objects and documents that we are using or a practical writing surface. The bookcase is available in various dimensions and made-to-measure.

*"Bei der physischen Realisierung eines Design Produktes besteht die Herausforderung darin, dem Material genauso viel Wert zu vermitteln wie der Form".*  
 Dies hat David Chipperfield zur Beschreibung seines BOOKSHELF gesagt.

Ursprünglich sollte dieser Artikel aus Eichenholz Typ "Briccole di Venezia" hergestellt werden, heute wird er in allen Holzsorten der Kollektion R1920 angeboten. Das Bücherregal ist vollständig aus massivem Holz und eignet sich zur Unterbringung von Büchern und Dokumenten. Die herausragende Fläche eignet sich hervorragend zum Abstellen von Gegenständen oder Dokumenten, die man gerade benutzt, oder als Schreibunterlage. Das Bücherregal ist in verschiedenen Größen und auf Anfrage auch als Maßanfertigung zu haben.

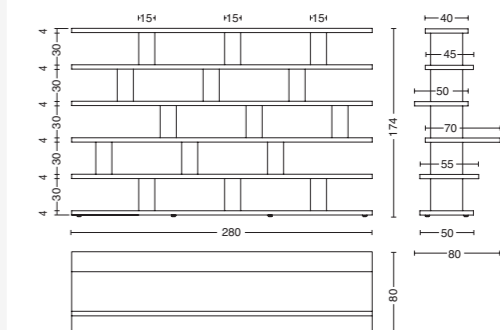

Cod. BOOKSHELF

H. 174 cm.  
 L. 240 - P. 80  
 L. 280 - P. 80  
 L. 320 - P. 80

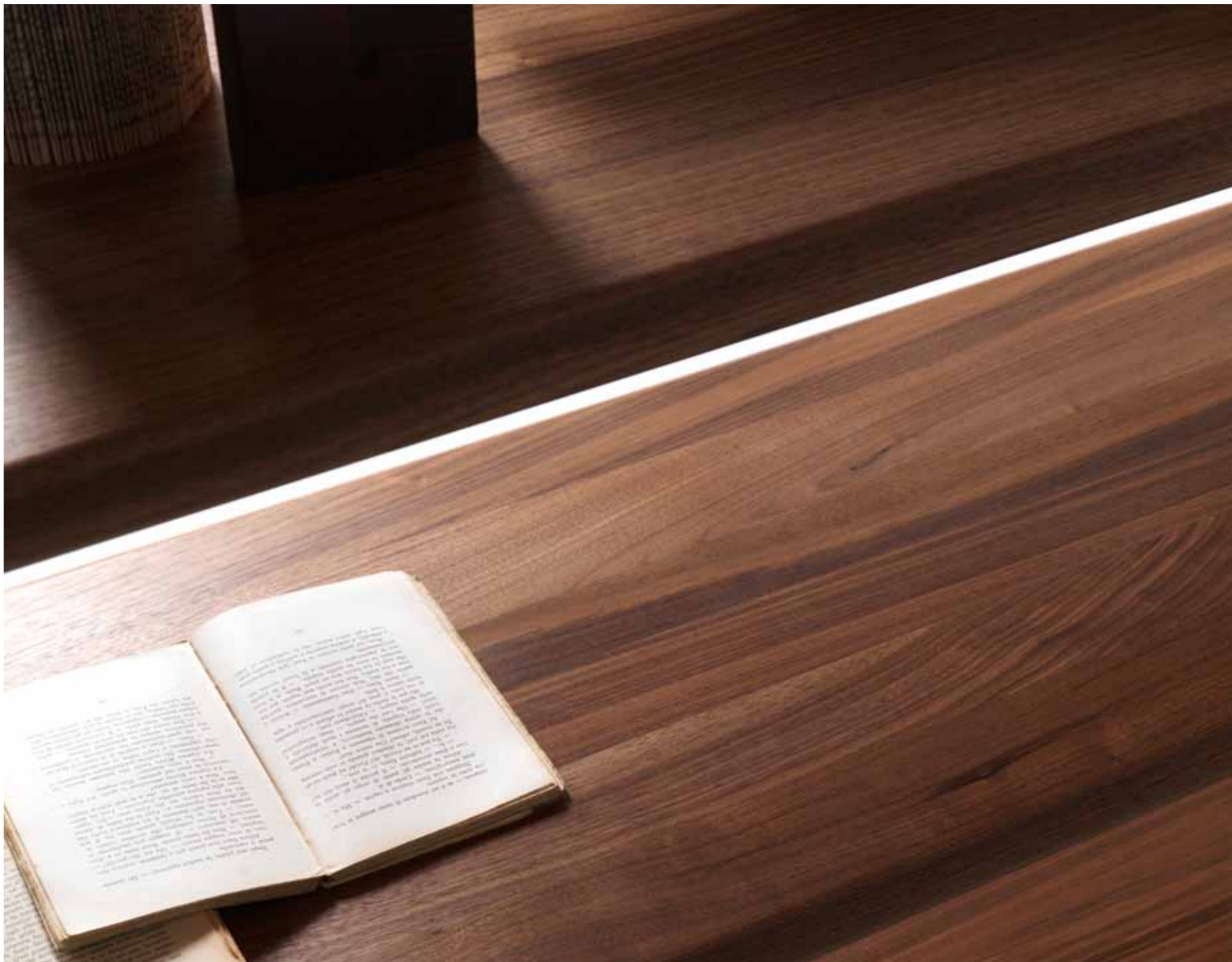

## TUBULAR

Design: Jamie Durie

Libreria realizzata da mensole in legno massello e struttura in metallo tubolare che da il nome alla collezione. Le mensole sono caratterizzate da bordi arrotondati e da fessate pensate per il fissaggio dei distanziali metallici. Il design, lineare ed essenziale, conferisce leggerezza all'intera libreria. Tubular bookshelf è componibile in base alle diverse esigenze e soluzioni d'arredo così come in tutte le essenze previste dalla Collezione R1920.

Book-case made of solid wood shelves with a tubular metal structure from which the collection takes its name. The main features of the shelves are the rounded edges and a groove into which the metal supports fit. The design, linear and essential, lends a sense of lightness to the whole unit. The Tubular bookshelf can be composed to meet different needs and solutions and is available in all the types of wood offered by R1920 Collection.

Bücherregal aus Massivholzfachböden und Metallrohrstruktur, die der Kollektion auch den Namen gibt. Die Fachböden weisen abgerundete Ränder und eine gefräste Rille auf, die zum Festmachen metallischer Distanzstücke gedacht ist. Das lineare und essentielle Design verleiht dem gesamten Bücherregal Leichtigkeit. Tubular bookshelf ist je nach Bedarf zusammenstellbar und in allen Hölzern erhältlich, die in der Kollektion R1920 vorgesehen sind.

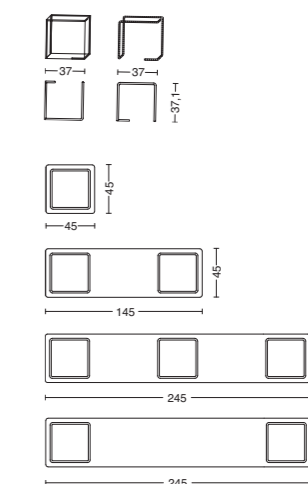
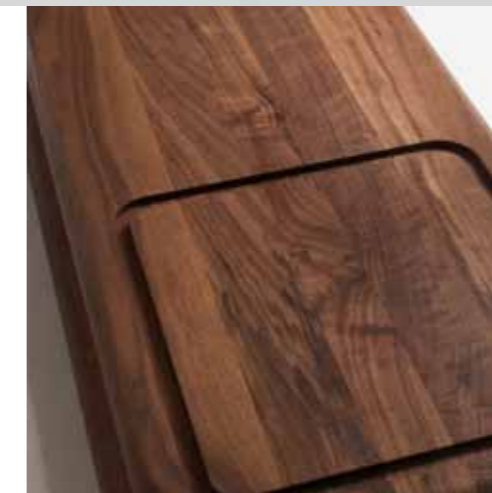

Cod. TUBULAR\_FRAME 1  
L. 37 - P. 37 - H. 37

Cod. TUBULAR\_SHELF 45  
L. 45 - P. 45 - H. 4

Cod. TUBULAR\_SHELF 145  
L. 145 - P. 45 - H. 4

Cod. TUBULAR\_SHELF 245  
L. 245 - P. 45 - H. 4

Cod. TUBULAR\_SHELF 245 TV  
L. 245 - P. 45 - H. 4



Cod. PROJECT 1  
L. 262,6 - P. 50 - H. 238

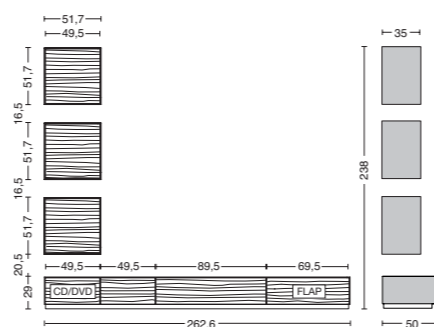

## RIALTO 2013 WALL UNIT

Design: Giuliano Cappelletti

Composizione modulare realizzabile su misura. Mobile "lowboard" in legno multistrato con struttura esterna in lamiera di metallo spessore 3 mm disponibile in ferro laccato trasparente opaco o colorato. Cassetti con frontali in noce, rovere o rovere "briccola", scorrevoli su binari metallici dotati di fermo a fine corsa e chiusura ammortizzata "bluemotion". I cassetti sono inoltre attrezzabili con porta CD e DVD in legno massello. A richiesta i vani del mobile "lowboard" possono essere attrezzati, anziché con cassetti, con frontali ad apertura a ribalta, per eventualmente ospitare apparecchiature tecnologiche e digitali. Gli elementi pensili sono invece indipendenti e posizionabili in base alle proprie esigenze.

Modular made-to-measure components. A "lowboard" piece in multilayer with external structure in 3 mm-thick sheet metal available in iron with a transparent, opaque or coloured finish. Drawers with front in walnut, oak or "Venetian briccola" oak, running on metal rails with an end-stop and "bluemotion" soft closing action. The drawers can also be equipped with CD and DVD rack in solid wood. Where requested, compartments in the "lowboard" unit can be fitted not with drawers but with "flap" fronts making it easier to house electronic and digital equipment. The overhead units are independent and can be positioned as required.

Modulare und als Maßanfertigung realisierbare Komponenten. "Lowboard" Möbelstück aus Multischichtholz mit Außenstruktur aus 3mm dickem, transparent mattlackiertem oder farbig lackiertem Eisenblech. Die Schubladen mit Vorderseite aus Nussbaum, Eiche oder "Briccola" Eiche gleiten auf Metallschienen, die mit Sperrklinke am Endanschlag und gedämpfter "Bluemotion" Schließung ausgestattet sind. Die Schubladen können außerdem mit CD und DVD Einsatz aus Massivholz ausgerüstet werden. Auf Anfrage können die Fächer des "Lowboard" Möbelstücks nicht mit Schubladen, sondern mit aufklappbaren Fronten versehen werden, um dort eventuell technische und digitale Apparaturen unterbringen zu können. Die Hängeelemente sind hingegen unabhängig voneinander und je nach Wunsch platzierbar.



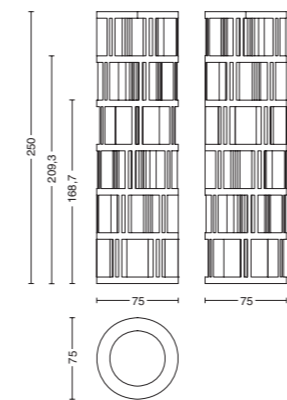

Cod. TORRE LIGNEA  
 Ø 75 - H. 168,7  
 Ø 75 - H. 209,3  
 Ø 75 - H. 250



## TORRE LIGNEA

Design: Michele De Lucchi

Libreria nata dall'estro di Michele De Lucchi con Davide Riva e realizzata in legno di cedro massello. Caratterizzata da numerosi vani e tagli verticali per dare maggiore dinamicità alla struttura, Torre Ligna è più di una semplice libreria: è una vera "opera d'arte", ogni volta unica perché ricavata da un tronco di legno di caratteristiche e dimensioni diverse, realizzata con l'ausilio di macchine ad altissima precisione. Torre Ligna è disponibile con base rotante e in varie altezze.

A bookcase made of solid cedarwood that is the fruit of the imagination of Michele De Lucchi with Davide Riva. Distinguished by its many compartments and its vertical cuts that give the structure greater dynamism, Torre Ligna is more than a simple bookcase: it is a true "work of art", always unique because it is cut with a high precision machine from a single block whose grain and size are always different. Torre Ligna is available with a revolving base and various heights.

Dies Bücherregal ist das Ergebnis der Phantasie von Michele De Lucchi und Davide Riva und wird aus massivem Zedernholz hergestellt. Torre Ligna zeichnet sich durch zahlreiche Fächer und vertikale Einschnitte aus, um der Struktur mehr Dynamik zu verleihen, und ist mehr als nur ein einfaches Bücherregal: es ist ein echtes "Kunstwerk", denn jedes Produkt ist ein Einzelstück, da es mit Hilfe hochpräziser Maschinen aus einem Holzstamm herausgearbeitet wird, der jedes Mal andere Charakteristiken und Abmessungen hat. Torre Ligna ist mit drehender Basis und in diversen Höhen erhältlich.



## VAMIZI SMALL

Design: Terry Dwan

Libreria realizzata con l'utilizzo di legno massello e distanziali in ferro laccato trasparente o colorato. Caratterizzata da un particolare gioco di rientranze e sporgenze delle mensole collegate tra loro tramite spalle in legno dando vita ad un movimento continuo dal basso verso l'alto. Disponibile nelle varie essenze a catalogo.

Solid wood bookshelf unit with dividers in iron finished with transparent or coloured lacquer. Its distinguishing mark is an unusual play of recesses and projections of the shelves connected by a wooden upright that lends continuous movement from bottom to top. Available in the various types of wood offered in our Catalogue.

Bücherregal aus Massivholz mit Distanzstücken aus transparent oder farbig lackiertem Eisen. Es zeichnet sich durch ein besonders Spiel mit Einbuchtungen und Vorsprüngen der untereinander mit Schulterstücken aus Holz verbundenen Fachböden aus, das für ständig wechselnde Bewegungen von unten nach oben sorgt. Erhältlich in den diversen Holzsorten gemäß Katalog.

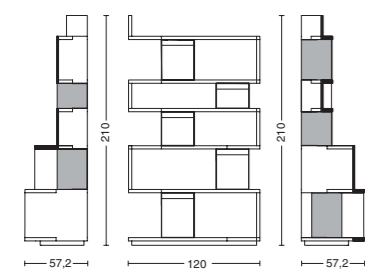

Cod. VAMIZI SMALL  
L. 120 - P. 57,2 - H. 210

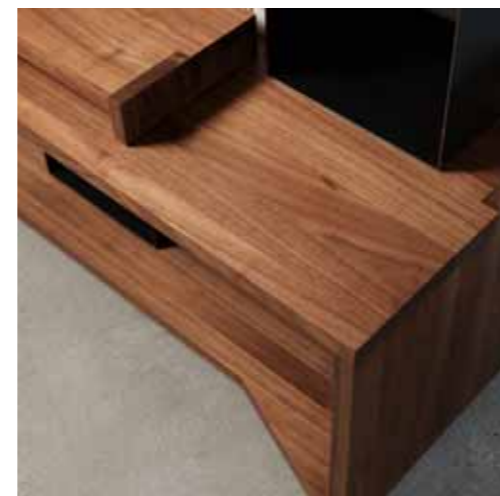

## VAMIZI TV WALL

Design: Terry Dwan

Libreria realizzata con l'utilizzo di legno massello e distanziali in ferro laccato trasparente o colorato. Caratterizzata da uno speciale gioco di rientranze e sporgenze delle mensole che si collegano tra loro tramite spalle in legno. Dotato anche di vani contenitori e di mensola porta TV. Disponibile nelle varie essenze a catalogo.

Solid wood bookshelf unit with dividers in iron finished with transparent or coloured lacquer. Its distinguishing mark is an unusual play of recesses and projections of the shelves connected by a wooden upright. Also provides container compartments and a shelf for a TV. Available in the various types of wood offered in our Catalogue.

Bücherregal aus Massivholz mit Distanzstücken aus transparent oder farbig lackiertem Eisen. Es zeichnet sich durch ein besonders Spiel mit Einbuchtungen und Vorsprüngen der untereinander mit Schulterstücken aus Holz verbundenen Fachböden aus. Mit Ablagemöglichkeiten und TV Fach ausgestattet. Erhältlich in den diversen Holzsorten gemäß Katalog.

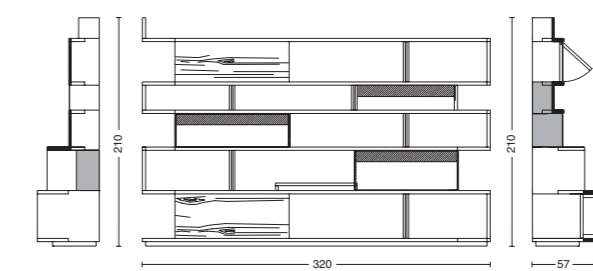

Cod. VAMIZI TV WALL  
L. 320 - P. 57,2 - H. 210





# Letti - Comodini - Armadi

## Beds - Night tables - Wardrobes

### Betten - Nachttische - Schränke

- 141 **NATURA 6**  
DESIGN: NATURA COLLECTION BY RIVA
- 142 **BAM BAM BED**  
DESIGN: TERRY DWAN
- 144 **RIALTO BED**  
DESIGN: GIULIANO CAPPELLETTI
- 146 **PIANO DESIGN BED**  
DESIGN: ARCH. RENZO PIANO E MATTEO PIANO
- 146 **KYOTO 6**  
DESIGN: NATURA COLLECTION BY RIVA
- 147 **PIANO DESIGN COMO**  
DESIGN: ARCH. RENZO PIANO E MATTEO PIANO
- 147 **KYOTO 5**  
DESIGN: NATURA COLLECTION BY RIVA
- 148 **PLANO**  
DESIGN: CR&S RIVA 1920
- 150 **TRUST CABINA ARMADIO**  
DESIGN: CR&S RIVA 1920
- 152 **FIAMMA LAMP**  
DESIGN: KARIM RASHID
- 154 **K-BLADE LAMP**  
DESIGN: CR&S RIVA 1920



### NATURA 6

Design: Natura Collection by RIVA

Nuova versione della serie Natura di Riva 1920, il letto Natura 6 presenta la testata realizzata in legno massello con nodi, caratterizzata dalla linea naturale del bordo superiore che mantiene la forma originale del tronco. La struttura del letto è anch'essa realizzata in legno massello, di noce o rovere, impreziosita dai dettagli dell'incastro a "coda di rondine" visibile tra pediera e longheroni.

New version of Riva 1920's Natura series. The Natura 6 bed has a headboard of solid wood with knots; the natural line of the top edge retains the original shape of the trunk. The structure of the bed is also in solid wood, walnut or oak, with craftsman details like "dove-tail" joints in evidence between the footboard and the sides.

Neue Version der Serie Natura von Riva 1920. Die Kopfseite des Betts Natura 6 ist aus Massivholz mit Ästen, charakteristisch ist der natürliche obere Rand, der die ursprüngliche Form des Stammes beibehält. Auch die Bettstruktur ist aus Massivholz, aus Nussbaum oder Eiche. Ein schönes Detail ist die zwischen Fuß- und Seitenteil gut zu sehende Schwalbenschwanzverbindung.

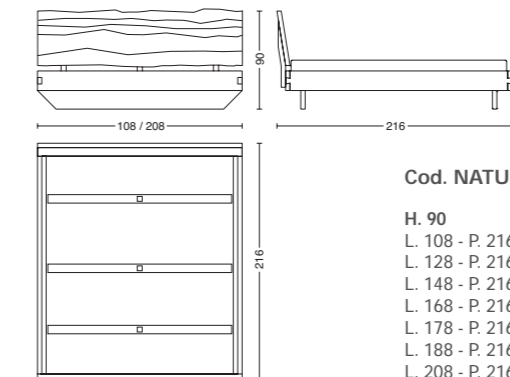



## BAM BAM BED

Design: Terry Dwan

Il letto Bam Bam nasce da una rivisitazione del letto Night Night disegnato dalla stessa designer. Letto completamente in legno massello: testata caratterizzata da una sequenza di doghe che si innestano con un gioco regolare in una fascia dal bordo naturale. La struttura e il basamento, essenziale e dalla forma squadrata, è disponibile in diverse misure ed essenze. Il letto Bam Bam è inoltre disponibile con materasso incassato nella struttura e con piano rete regolabile in altezza.

The Bam Bam bed is the result of revisiting the Night Night bed created by the same designer. The bed is made entirely of solid wood: what characterises the headboard is a sequence of batons that rise at regular intervals to fit into a headboard. The structure and the base, essential and squared, are available in different sizes and types of wood. The Bam Bam bed is also available with a mattress sunk into the structure and with a height-adjustable base.

Das Bettmodell Bam Bam ist eine Neuversion des Bettmodells Night Night, das von der gleichen Designerin entworfen wurde. Das Bett ist vollständig aus massivem Holz: nebeneinander gereihete Latten im Kopfteil schließen an der Oberseite mit einem Holzstreifen ab, der einen schönen natürlichen Rand aufweist. Struktur und Untergestell sind von essentieller und quadratischer Form und in diversen Größen und Hölzern zu haben. Das Bettmodell Bam Bam ist außerdem mit in Struktur eingelassener Matratze und höhenverstellbarer Liegefläche zu haben.

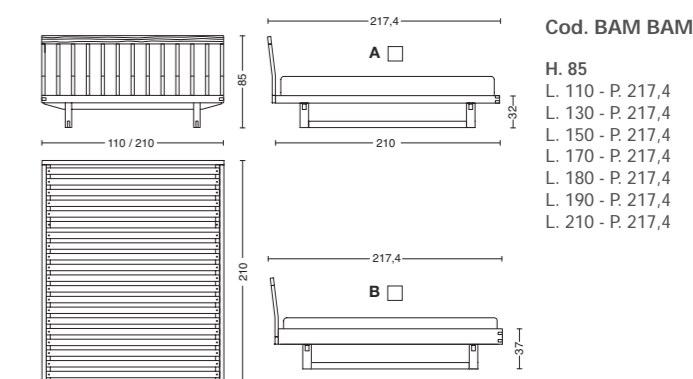



## RIALTO BED

Design: Giuliano Cappelletti

A completamento della linea di arredi appartenenti alla collezione Rialto, l'arch. Giuliano Cappelletti progetta un letto dalle medesime caratteristiche. Linee squadrate, doghe a vista sulla testata e giroletto sospeso, caratterizzano ed identificano questo letto. Disponibile con comodini sospesi integrati nella testata (come nella versione in foto) oppure senza comodini con testata a filo del giroletto. Letto realizzabile anche su misura.

Enriching the line of elements belonging to the Rialto collection, Giuliano Cappelletti has designed a bed with the same characteristics: squared shape, visible slats on the headboard and raised bed surround. Available with raised bedside units attached to the headboard (as in the version illustrated) or without these units and with the headboard level with the surround. The bed can also be made to measure.

Zur Vervollständigung der zur Rialto Kollektion gehörenden Einrichtungselemente hat der Architekt Giuliano Cappelletti ein Bett mit den gleichen Merkmalen entworfen. Quadratische Linien, sichtbaren Latten im Kopfteil und aufgehängte Bettumrandung zeichnen dieses Bett aus. Erhältlich mit aufgehängten und im Kopfteil integrierten Nachttischen (wie bei der Version im Foto) oder ohne Nachttische mit Kopfteil, das bis zur Bettumrandung reicht. Bett auch als Maßanfertigung realisierbar.

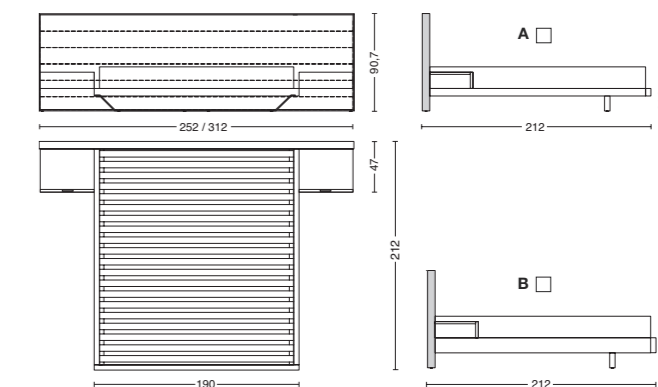

Cod. RIALTO-BED

H. 90,7  
L. 252 - P. 212  
L. 272 - P. 212  
L. 282 - P. 212  
L. 292 - P. 212  
L. 312 - P. 212



## PIANO DESIGN BED

Design: Studio Piano - Arch. Renzo Piano e Matteo Piano

Letto nato dal talento creativo dello Studio Piano e sintesi dell'incontro tra forza e leggerezza: la prima rappresentata dal legno massiccio e dai toni caldi; la seconda dai sottili elementi tensori in acciaio.

Thanks to the creativity of Studio Piano here is a bed which is fusion of power and lightness: the former represented by the solid wood and warm colours; the second by the fine steel struts.

Dies Bett entspringt dem kreativen Talent von Studio Piano und stellt eine Verschmelzung von Kraft und Leichtigkeit dar: die Kraft wird durch das massive Holz und die warmen Töne repräsentiert, die Leichtigkeit durch die dünnen Spannelemente aus Stahl.

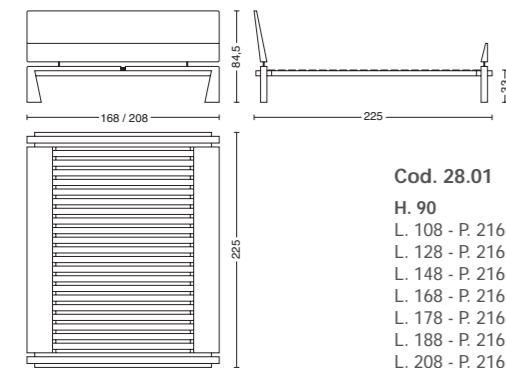

**Cod. 28.01**  
H. 90  
L. 108 - P. 216  
L. 128 - P. 216  
L. 148 - P. 216  
L. 168 - P. 216  
L. 178 - P. 216  
L. 188 - P. 216  
L. 208 - P. 216

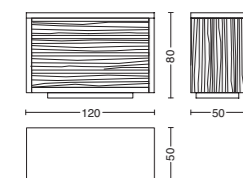

**Cod. KYOTO 6**  
L. 120 - P. 50 - H. 80

Cassettera realizzata mantenendo la tradizione del cassetto assemblato con incastri a coda di rondine e arricchito dalla praticità dello scorrimento su binari metallici. Ogni cassetto è realizzato uno a uno, assemblato e testato dai nostri esperti falegnami. L'impugnatura per l'apertura dei cassetti è ottenuta grazie a una fresata sul frontale del cassetto. Disponibile anche su misura.

Chest of drawers which continues the craft tradition of the drawer assembled using dove-tail joints, here modernized with the smooth-moving efficiency of metal runners. Each drawer is made individually, assembled and tested by our expert cabinet makers. The grip for opening the drawers is created by a groove cut into the front of the drawer. Made-to-measure versions are also available.

Kommode mit Schubladen, die nach dem traditionellen Schwalbenschwanzprinzip zusammengesetzt wurden und auf praktischen Metallschienen gleiten. Jede Schublade wird einzeln angefertigt und von unseren erfahrenen Tischlern zusammengesetzt und getestet. Die Schubladen lassen sich durch eine gefräste Mulde öffnen, die an der Vorderseite ausgeführt wird. Auch als Maßanfertigung zu haben.



## KYOTO 6

Design: Natura Collection by RIVA



## KYOTO 5

Design: Natura Collection by RIVA

Linea di comodini e cassettera con struttura in legno multistrato e legno massello. Il top è sostenuto da sottili elementi in acciaio che riprendono il design dell'omonima libreria. I cassetti in legno massello sono assemblati tramite la tradizionale tecnica di incastro a "coda di rondine" e scorrimento su guide metalliche.

A line composed of bedside tables and a chest of drawers with a structure in multilayer and solid wood. The top is supported by thin steel elements that echo the design of the bookcase of the same name. The solid wood drawers are put together using the traditional technique of "dovetail joints" and run on metal rails.

Nachttisch- und Kommodenserie mit Struktur aus Multischicht- und Massivholz. Das Top wird von dünnen Stahlelementen gestützt, die das Design des gleichnamigen Bücherregals aufgreifen. Die Schubladen aus massivem Holz werden mit Hilfe der traditionellen Schwalbenschwanzmethode zusammengesetzt und gleiten auf Metallführungen.

Comodino con struttura e top in legno multistrato. Cassetto in legno massello assemblato tramite la tradizionale tecnica di incastro a "coda di rondine" e scorrimento su guide metalliche. La maniglia è ricavata grazie a una particolare lavorazione di fresatura sullo spessore del frontale del cassetto.

A bedside table with structure and top in multilayer. A solid wood drawer assembled using the traditional technique of "dovetail joints" and run on metal rails. The handle is created by the milling of a groove on the front of the drawer.

Nachttisch mit Struktur und Top aus Multischichtholz und Massivholz. Die Schublade aus Massivholz wird nach der traditionellen Schwalbenschwanzmethode zusammengesetzt und gleitet auf Metallführungen. Der Griff wird durch eine besondere Fräsbearbeitung in Form einer Rille auf der Schubladenvorderseite erzielt.

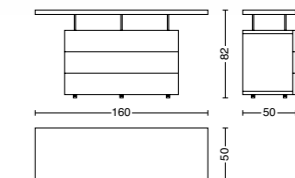

**Cod. 28.02.1**  
L. 160 - P. 50 - H. 82

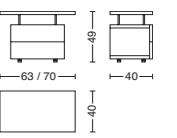

**Cod. 28.03.1**  
L. 63 - P. 40 - H. 49

**Cod. 28.03.2**  
L. 70 - P. 40 - H. 49

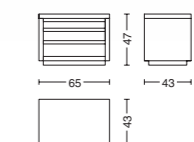

**Cod. KYOTO 5**  
L. 65 - P. 43 - H. 47



## PLANO

Design: CR&S Riva 1920

Armadio ad ante complanari che si contraddistinguono per la maniglia fresata nell'anta permettendo una facile presa per l'apertura della stessa. Realizzato in tutte le essenze a catalogo con attrezzatura interna disponibile anche in essenza cedro o nella stessa essenza della struttura esterna. Plano è inoltre realizzabile su misura con la possibilità di personalizzare la disposizione degli elementi interni a (cassetti, strisce led, ripiani, etc.). L'armadio Plano è presentato in foto con le ante realizzate nella speciale finitura in rovere "pressato": un effetto che evidenzia e risalta in rilievo la venatura del legno (disponibile solo in essenza rovere).

A wardrobe with coplanar doors that are identifiable by the groove cut into the surface of the door to provide a comfortable grip. Available in all the types of wood in our catalogue and interior equipment also available in cedarwood or the same wood as the external structure. Plano can also be made-to-measure and the customer can also personalise the arrangement of the internal elements (drawers, LED strip, shelves, etc.). The doors of the Plano wardrobe illustrated here have a special "pressed" oak finish: an effect that brings out the beauty of the wood grain (only available in oak).

Schrank mit komplanaren Türen, die sich dadurch auszeichnen, dass die in die Tür gefräste Griffmulde ein bequemes Greifen und Öffnen gestattet. Aus allen im Katalog befindlichen Holzsorten herstellbar, Innenausstattung kann aus Zedernholz oder aus dem gleichen Holz der Außenstruktur angefertigt werden. Plano ist außerdem als Maßanfertigung erhältlich und die Anordnung der internen Elemente (Schubladen, Led Streifen, Einlegeböden etc.) kann individuell ausgeführt werden. Im Foto wurden die Türen des Kleiderschrankmodells Plano mit dem besonderen Oberflächenfinish Eiche "gepresst" realisiert: ein Effekt, der die Holzmaserung deutlich unterstreicht und hervorhebt (nur bei Eiche verfügbar).

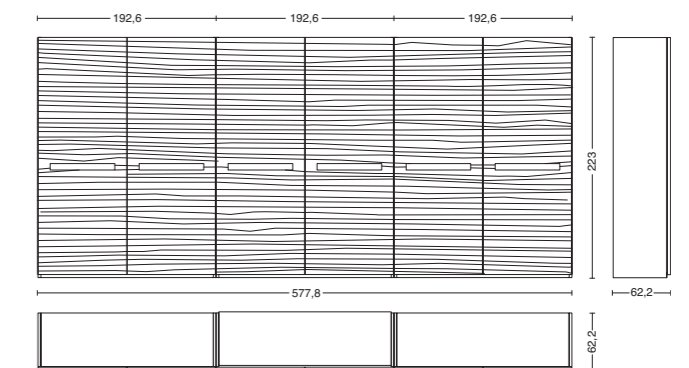
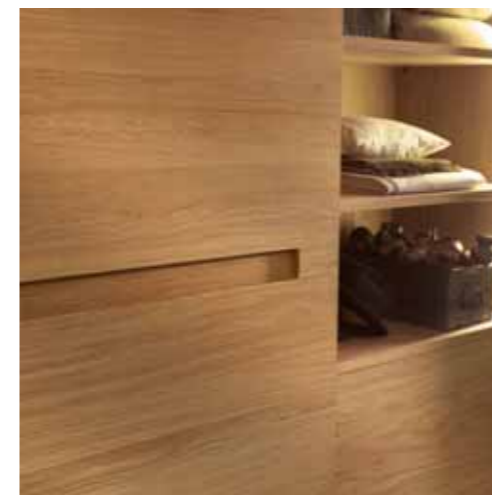

Cod. PLANO 3  
L. 577,8 - P. 62,2 - H. 223



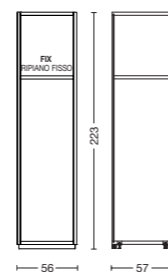

Cod. TRUST\_50  
L. 50 - P. 57 - H. 223

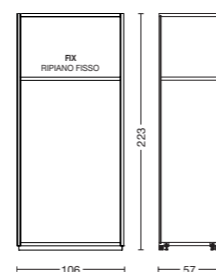

Cod. TRUST\_100  
L. 100 - P. 57 - H. 223

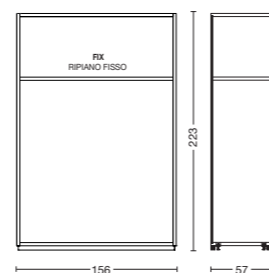

Cod. TRUST\_150  
L. 150 - P. 57 - H. 223



## TRUST CABINA ARMADIO

Design: CR&S Riva 1920

Dall'esperienza che contraddistingue Riva 1920 nella realizzazione di mobili e ambienti su misura, nasce la cabina armadio TRUST. Elementi completamente personalizzabili in base alle dimensioni del locale da arredare e in base alle esigenze del cliente. Una cabina armadio realizzata completamente in legno e multistrato di cedro, un'essenza nobile e preziosa usata in passato dai migliori ebanisti europei per la realizzazione di arredi di altissima qualità anche per le sue proprietà antitarne. La cabina armadio TRUST è corredata da molti accessori utili per fare di questo elemento un luogo personale e intimo della propria casa. Vani porta scarpe con ripiani obliqui, ripiani porta camicie estraibili, cassetti con divisori per cinture o per altri piccoli oggetti e vani di varie altezze con barre appendibili sono solo alcuni degli accessori che si possono integrare nella cabina armadio TRUST. A richiesta sono inoltre disponibili i vani con illuminazione a LED. La cabina armadio TRUST è disponibile inoltre in tutte le essenze previste dalla Collezione Riva 1920.

The TRUST walk-in closet is the fruit of several years proven experience in the production of custom made furniture. Its elements are entirely customisable according to the client's own needs and wishes. The TRUST walk-in closet is entirely made of multilayer and solid cedar wood, a truly aristocratic type of wood, used in the past by the best cabinet-makers in Europe for making high quality furniture. It is also a natural remedy against moths. The TRUST closet is provided with a number of useful accessories to make it a personal, intimate part of one's home. Shoe storage areas provided with slanting panels, pull-out shirt shelves, drawers with dividers for belts and other small objects and compartments of different heights with bars for clothes hangers: these are just a few of the available elements to build the cabinet of your dreams. Upon request, it is possible to provide the cabinet with led lighting. The TRUST walk-in-closet is available in all the wood types of the Riva 1920 collection.

Aus der Erfahrung, die Riva 1920 bei der Herstellung maßangefertigter Möbel und Einrichtungsgegenstände sammeln konnte, stammt die Schrankkabine TRUST. Die Elemente sind vollständig individuell lieferbar, je nach Größe des einzurichtenden Raumes und je nach Bedarf des Kunden. Eine Schrankkabine, die komplett aus Massivholz und Zedermehrschichtholz realisiert wird, eine edle und hochwertige Holzart, die in der Vergangenheit von den besten Möbeltischlern auch dank ihrer Mottenschutzwirkung zur Herstellung feinsten Möbelstücke verwendet wurde. Die TRUST Schrankkabine verfügt über ein umfangreiches Zubehörsortiment, was dies Produkt zu einem persönlichen und intimen Ort Ihrer Wohnung macht. Geneigte Fächer für Schuhe, ausziehbare Fachböden für Hemden, Schubladen mit Unterteilungen für Gürtel oder andere kleine Gegenstände und unterschiedlich hohe Fächer mit Kleiderstangen sind nur einige der Elemente, die sich in die TRUST Schrankkabine integrieren lassen. Auf Anfrage ist Beleuchtung mit LED verfügbar. Die TRUST Schrankkabine ist in allen Holzsorten der Kollektion Riva 1920 lieferbar.



## FIAMMA LAMP

Design: Karim Rashid

Dalle linee sinuose e armoniche tipiche della progettualità di Karim Rashid, nasce Fiamma Lamp, un elemento scultoreo che rappresenta l'incontro tra il legno e la tecnologia. La luce a LED corre lungo il profilo della lampada connotandola come oggetto di design unico.

With its sinuous and rhythmic lines, typical of designs by Karim Rashid, Fiamma Lamp is a sculptural element, a meeting of wood and modern technology. The LED light runs along the edge of the lamp creating a unique design effect.

Mit ihrer welligen und harmonischen Linienführung, die so typisch für den Designer Karim Rashid ist, entsteht Fiamma Lamp, ein bildhauerisches Element, das eine Verschmelzung von Holz und Technologie darstellt. Das LED-Licht läuft am Rand des Lampenprofils entlang und macht aus ihr einen einzigartigen Designgegenstand.

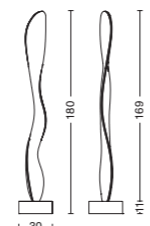

Cod. FIAMMA  
L. 30 - P. 30 - H. 180





## K-BLADE LAMP

Design: CR&S Riva 1920

Tradizione e tecnologia si incontrano e si fondono insieme per dare vita ad un progetto che unisce il legno Kauri millenario e la tecnologia "Oled" Organic Light Emitting Diode di tecnologia Philips, per un risultato di grande impatto che coniuga un design essenziale con la nuova frontiera della luce. Disponibile anche in legno noce o rovere.

Tradition and technology meet and coalesce to create a design of great impact that unites ancient Kauri wood and the latest in Philips' technology, "Oled" Organic Light Emitting Diode, a fusion of minimalist design and the new frontier in the world of lighting. Also available in walnut or oak.

Tradition und Technologie treffen aufeinander und vereinen sich, um einem Projekt ins Leben zu verhelfen, das tausendjähriges Kauri Holz mit der "Oled" Organic Light Emitting Diode, einer Technologie von Philips, verbindet. Mit einem effektvollen Ergebnis, das essentielles Design mit neuen Beleuchtungsgrenzen in Einklang bringt. Verfügbar auch aus Nussbaum- oder Eichenholz.

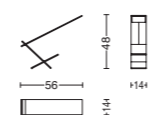

Cod. K\_BLADE  
L. 56 - P. 14 - H. 48

# Campionario Sample charts Muster

- 156 **ESSENZE E FINITURE**  
WOOD TYPES AND FINISHES\_HOLZ UND OBERFLÄCHEN
- 158 **PELLE UTAH**  
UTAH LEATHER - UTAH LEDER
- 159 **BASI E STRUTTURE IN METALLO E FINITURE**  
METAL BASES, STRUCTURES AND FINISHES  
METALLSTRUKTUREN, TISCHBEINE UND OBERFLÄCHEN





**NOCE OLIO**  
Walnut, oil  
Nussbaum geölt



**NOCE CON NODI, OLIO**  
Walnut with knots, oil  
Nussbaum mit Knoten geölt



**CILIEGIO OLIO**  
Cherrywood, oil  
Kirschbaum geölt



**ACERO CERA**  
Maple, wax  
Ahorn, gewachst



**ROVERE OLIO**  
Oak, oil  
Eiche geölt



**ROVERE CON NODI OLIO**  
Oak with knots, oil  
Eiche mit Knoten geölt



**ROVERE CERA**  
Oak, wax  
Eiche gewachst



**ROVERE SBIANCATO CERA**  
Whitened oak, wax  
Eiche geweißt, gewachst



**CEDRO GREZZO**  
Cedarwood, raw  
Zedernholz unbehandelt



**KAURI "LEVIGATO", OLIO**  
Kauri "machine sanded", oil  
Kauri "geschliffen", geölt



**KAURI "PIALLATO", OLIO**  
Kauri "hand sanded", oil  
Kauri "gehobelt", geölt



**ROVERE "BRICCOLE" CERA**  
"Briccola" oak, wax  
"Briccola" Eiche, gewachst.

*Sono possibili lievi difformità cromatiche dovute alla stampa tipografica.  
Slight colour differences may be found on the surface as a consequence of printing.  
Geringe Farbweichungen sind druckbedingt möglich.*

## ESSENZE E FINITURE - WOOD TYPES AND FINISHES - HOLZ UND OBERFLÄCHEN

Tutti gli articoli della Collezione RIVA 1920, se non diversamente specificato, sono disponibili in quattro diverse essenze di legno: **ciliegio, acero, rovere e noce americano, tutti legni di forestazione certificata**. A richiesta, e solo per prodotti specifici, anche in legno di **Kauri Millenario, cedro e rovere "Briccola"**. La finitura (ad eccezione dei prodotti in cedro) è a base di oli vegetali, e cere non dannosi per la salute, che consente di risaltare al massimo le venature del legno con naturale splendore. Le diverse tonalità di colore del legno sono da considerarsi un **pregio** in quanto sinonimo di **materia prima naturale**, senza coloranti o fibre artificiali aggiunte.

All the products of the RIVA 1920 Collection, unless otherwise specified, are available in four different wood types: **cherry, maple, oak and walnut**, all coming from controlled forests. Upon request, and only for specific products, **millenary Kauri wood, cedarwood and "Briccola" oak** can be used. The final effect is obtained through the application of a vegetable oil or wax finish (except for products made of cedarwood that are kept natural and are not oiled), a kind of materials that does not harm health and contributes to bring out the beauty of wood grains without altering its naturalness. Wood shades beautifully display the natural variations in wood, reminding us that what we see is a natural raw material, not altered by artificial fibres or colorants.

Die Produkte von der RIVA 1920 Kollektion, wenn nicht anders angegeben, sind in vier verschiedene Holzarten erhältlich: **Kirschbaum, Ahorn, Eiche** und amerikanischer **Nussbaum** aus bestätigten Wiederaufforstungsgebieten. Auf Wunsch, aber nur für angegebene Artikel, ist auch **tausendjähriger Kauri, Zedernholz und "Briccola" Eiche** erhältlich. Die charakteristische Oberflächenbehandlung mit Pflanzenölen oder Wachse ermöglichen der Holzmaserung sich im natürlichen Erscheinungsbild hervorzuheben, ohne die Gesundheit zu gefährden. Eventuelle Farbunterschiede die in einem Möbelstück auftreten können sind ein **Echtheitsmaterial** für Möbel in Holz mit rein natürlicher Rohstoffe und Verarbeitungsweise.

## INFORMAZIONI IMPORTANTI SUL LEGNO MASSELLO

Il legno è vivo! E 'quindi importante che il legno, così come il legno massello, siano trattati correttamente. Con una cura adeguata e costante, di solito il legno è molto più durevole di quanto si pensi. Il legno spesso si può muovere in relazione all'umidità e alla temperatura dell'ambiente in cui si trova. Capita che nella nostra vita quotidiana non sempre è possibile mantenere delle condizioni ottimali per la vita del legno, ed è quindi nella natura del legno aumentare o diminuire di dimensione a seconda del clima. Tolleranze di circa **0,5 - 1,0%** su top o superfici in legno massello incollati sono pertanto normali e non possono essere motivo di contestazione o reclamo. Un fattore molto importante che deve essere osservato in presenza di mobili in legno massello è la percentuale di umidità nell'aria della stanza. Per una perfetta tenuta del legno massello è raccomandato che nell'ambiente vi sia una umidità relativa intorno al **50-55%**, che si può ottenere con l'utilizzo di appositi umidificatori o depuratori d'aria. Ogni mobile in legno è unico nella sua intensità di colore e di venatura. I mobili con finitura a olio e cera possono avere tonalità leggermente più scure o più chiare e queste piccole variazioni non possono essere evitate in quanto caratteristiche tipiche del legno naturale. Il legno inoltre reagisce alle diverse condizioni di luce. Di norma i legni di colore chiaro tendono a diventare più scuri, mentre i legni di tonalità più scura tendono a diventare più chiari. Si consiglia quindi, per evitare differenze di tonalità sulla superficie di un mobile, di non posizionare oggetti per lungo tempo su uno stesso punto.

## CERA PER LAVORAZIONE LEGNO CON NODI

I legni nella versione "con nodi" sono trattati con una speciale cera di colore nero che viene riscaldata e portata allo stato liquido per essere poi inserita nel nodo. Una volta raffreddata a temperatura ambiente, ritorna allo stato solido e ottura completamente il nodo del legno. Eventuali effetti di "cristallizzazione" della cera o differenze di tonalità di colore sulla superficie del tavolo in corrispondenza del nodo sono del tutto normali e possono essere attenuati utilizzando la paglietta d'acciaio del nostro set manutenzione. Anche il numero dei nodi e la loro dimensione presenti nel top del tavolo non sono motivo di contestazione bensì una caratteristica del legno massello della versione "con nodi" trattato con oli e cere naturali. Prendersi cura di un mobile in legno è semplice: è sufficiente, quando sarà necessario, ripristinare la finitura. Per questo, a chi acquista un mobile RIVA 1920, viene consegnato un kit di manutenzione con un flacone della finitura, un panno per la polvere, una paglietta in lana d'acciaio per togliere eventuali aloni o graffi, un panno per stendere la finitura e i guanti.

## IMPORTANT INFORMATION ON SOLID WOOD

Wood is alive! It is thus important that wood, including solid wood, is treated correctly. If taken care of adequately and constantly, solid wood lasts much more time than ever thought! Wood is often subjected to movements as a consequence of the humidity and the temperature of the environment in which it is located. In our daily life, it is possible that optimal conditions for wood to live in are not fulfilled, and it is thus normal for wood to increase or decrease its own dimensions according to the climate. Variations of **0,5 - 1,0%** on solid wood table tops or surfaces are normal and cannot represent a reason for claims. A very important element that should be considered when dealing with solid wood furniture is humidity. For a good holding of solid wood, it is recommended that the humidity of the room is around **50 - 55 %** - it is possible to achieve such result by using proper humidifiers and air purifiers. Each and every wooden piece of furniture features unique colour shades and grains. Pieces of furniture finished with oil and wax can feature slightly darker or lighter shades and such nuances cannot be avoided since they are typical features of natural wood. Wood also reacts to different light conditions. Normally, light-shade woods tend to turn darker, whereas dark-shade woods tend to turn lighter. It is suggested, so to avoid colour differences over the top of one single element, not to leave the same item over a surface for a long period of time.

## NATURAL WAX TO TREAT WOOD KNOTS

Wood knots are treated with a special black-coloured wax that is heated and once liquefied, it is poured onto the knot. Time is allowed for the wax to cool down at room temperature. Once it solidifies, it thoroughly covers up the wood knot. It is possible to encounter wax "crystallization" effects or colour variations over the table top. This is a normal consequence of the waxing process and the spots can be faded through the use of a steel wool provided with the maintenance kit. Also the number of knots and their dimensions over the table top cannot be a reason for complaints, since they represent a natural feature of true solid wood "with knots", finished with natural oils or waxes. Taking care of a furnishing item made of wood is simple: restore the finish whenever it is necessary. For this reason, all of our customers receive a Maintenance Kit that includes: a bottle containing oil, a dust cloth, a steel wool to remove any stains or marks, a cloth to spread oil and a pair of gloves.

## WICHTIGE HINWEISE ZU MASSIVHOLZ

Holz lebt! Es ist deshalb wichtig Vollholz, wie Massivholz richtig zu behandeln. Bei guter Pflege sind sie in der Regel wesentlich strapazierfähiger als Möbel anderer Materialien. Holz arbeitet abhängig von der Luftfeuchtigkeit und Temperatur. Da optimale Bedingungen im Alltag nicht dauerhaft vorhanden sind, liegt es in der Natur des Holzes sich je nach Klima zu weiten oder zu schrumpfen. Toleranzen von ca. **0,5 - 1,0 %** sind deshalb bei fest verleimten Hölzern normal und kein Grund zur Beanstandung. Ein sehr wichtiger Punkt den Sie bei Ihren Holzmöbeln unbedingt beachten sollten, ist das Raumklima. Voll - wie Massivhölzer benötigen eine relative Raumfeuchtigkeit von **50 - 55 %**, die nur durch zusätzlich im Raum aufgestellte Luftbefeuchter bzw. Luftwäscher erreicht wird. Reines Vollholz ist in seiner Farbintensität und Maserung einzigartig. Möbelstücke können also etwas dunkler oder heller ausfallen. Auch lassen sich Farbunterschiede in einem Möbelstück nicht vermeiden. Holz reagiert auf Lichteinstrahlung unterschiedlich. So dunkeln helle Hölzer nach und dunkle Hölzer werden heller. Es ist deshalb ratsam, die darauf befindlichen Gegenstände des Öfteren umzustellen.

## WACHS FÜR DIE BEARBEITUNG VON HOLZ MIT KNOTEN

Die Tischplatte in der Version „mit Knoten“ sind mit einem speziellen schwarzen Wachs behandelt, welcher durch Erhitzen flüssig in die offenen Poren eingelassen wird. Nachdem er auf Raumtemperatur abgekühlt ist nimmt der Wachs seine Solide Form an und füllt den Holzknoten vollständig aus. Eventueller Effekt von „Kristallisierung“ von dem Wachs oder Unterschiede des Farbton um den Knoten kann vorkommen und ist vollkommen normal. Mit Hilfe des Stahlschwämmchens aus unserem Pflegesets kann der Effekt gemindert werden. Ebenfalls geben Anzahl und Größe der vorhandenen Knoten keinen Anlass zur Reklamation, sondern unterstreicht den Charakter von Massivholz „mit Knoten“, vollendet auf natürliche Basis mit natürlichen Ölen und Wachs. Die Pflege eines Holzmöbels ist sehr einfach: wenn erforderlich, ist die Feinbearbeitung wieder zu erneuern. Hierfür wird Ihnen bei Erwerb eines Riva-Möbels eine Pflege mitgeliefert. Dieses Pflegeset enthält ausser Pflegeanleitung, ein Fläschchen Öl, ein Staubtuch, weiche Stahlwolle für die Entfernung von eventuellen Kratzern oder Rändern und Handschuhe.





UTAH BLACK



UTAH TAUPE



UTAH CHOCOLAT



UTAH SAHARA



UTAH KANYON



UTAH HAVANA



UTAH MATTONE



UTAH SAVANE



UTAH WISKY

Sono possibili lievi difformità cromatiche dovute alla stampa tipografica.  
Slight colour differences may be found on the surface as a consequence of printing.  
Geringe Farbweichungen sind druckbedingt möglich.

## PELLE UTAH - UTAH LEATHER - UTAH LEDER

Pelle per arredamento nabuccato e cerato con effetto invecchiato, lavorato con paraffine, con leggero effetto "pull-up" e finitura opaca / semilucida. Spessore: 2,8 - 3,0 mm. Le differenze di tonalità riscontrabili, talvolta, tra pelle e pelle, sono dovute al trattamento all'anilina, che per contro restituisce trasparenza e profondità; caratteristiche immancabili delle pelli lavorate nel pieno rispetto di pregi e difetti del cuoio naturale. La pelle UTAH è un materiale naturale e perciò occorrono alcune avvertenze per mantenere le caratteristiche inalterate nel tempo. La pelle UTAH è già trattata con materiali idrorepellenti e pertanto sopporta una certa resistenza ai liquidi. E' tuttavia consigliabile, in caso di macchie di liquidi, di rimuovere immediatamente il liquido con un panno asciutto e tamponare con carta assorbente prima che il liquido venga assorbito dalla pelle. Inoltre in caso di macchie secche si consiglia una pulizia con una gomma per matita. Non usare altri strumenti abrasivi o detergenti chimici in quanto potrebbero irrimediabilmente rovinare la superficie e la qualità della pelle.

Leather for furnishing sueded and waxed, with aging effect, worked with paraffin, with a light pull-up effect; finish mat or demi luster. Thickness: 2,8 - 3,0 mm. The differences in tonality which may be sometimes seen between leather to leather are due to the use of aniline, which for its use grant transparency and deepness, unfailing characteristic of leather worked in the full respect of the values and of the imperfections of the natural leathers. UTAH leather is a natural material that requires proper care to maintain its characteristics over time. UTAH leather is treated with water-repellent materials and thus can be resistant to liquids. However, in case of stains caused by liquids, we suggest you to remove the stain immediately with a dry cloth and then to dry making a circular movement with some paper towel before the liquid is absorbed by leather. Moreover, in case of dry stains, we advise you to clean the leather with a rubber for design. Never use other abrasive products or chemical detergents. The problem could get worse and the surface and the leather quality could be damaged.

Polsterleder, Nubuk Dickleder - Oberfläche mit Wachs behandelt; „vintage“ Effekt, Bearbeitung mit Paraffin, mit einem leichten „Pull-Up“ Effekt, matt/halb glänzend. Stärke: 2,8 - 3,0 mm. Eventuelle Farbunterschiede zwischen den Hauten sind aufgrund der Bearbeitung mit Anilin möglich. Sie geben dem Leder Farbe und Tiefe. Diese sind Hauptmerkmale von einem natürlichen Material wie Leder. Das Leder UTAH ist ein natürliches Material soll sehr sorgfältig behandelt werden, damit es seine Besonderheiten unverändert behält. Das Leder UTAH wird mit wasserabweisenden Mitteln bearbeitet deswegen zeigt es eine hohe Resistenz bei Flüssigkeiten. Trotzdem raten wir, im Fall das Tropfen oder Flüssigkeiten auf die Fläche kommen, diese sofort mit einem sauberen, trockenen, weichen Tuch und Löschpapier zu reinigen bevor das Leder die Flüssigkeit aufsaugt. Trockene Flecken können mit einem Radiergummi entfernt werden. Vermeiden Sie Schleifmittel oder chemische Substanzen auf der Fläche. Sie wird damit irreparabel beschädigt.

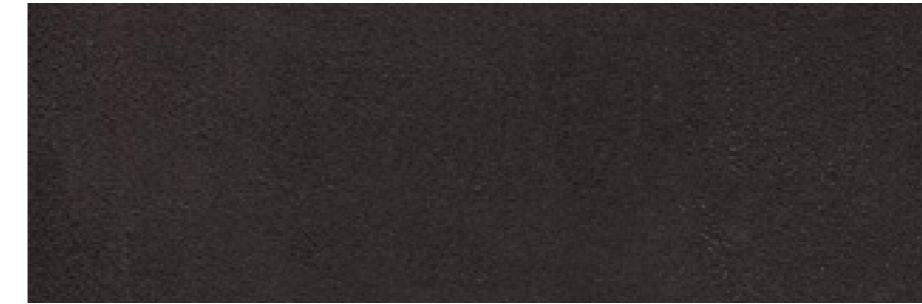

FERRO color NATURALE, finitura a olio.  
NATURALLY coloured IRON, oil finish.  
ROHEISEN NATURFARBIG, geölt.

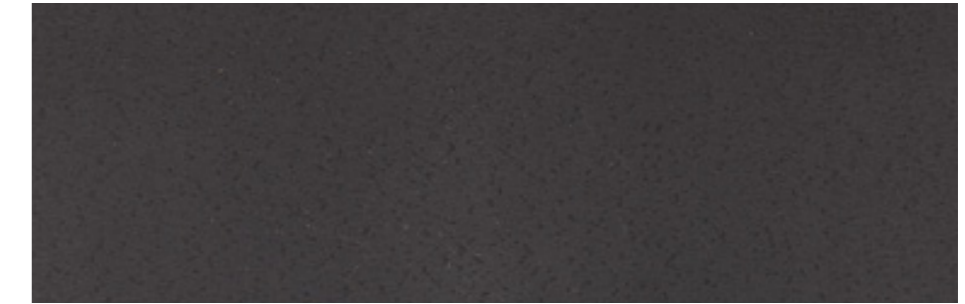

FERRO color NATURALE, finitura laccata trasparente opaco.  
NATURALLY coloured IRON, mat transparent finish.  
ROHEISEN NATURFARBIG, transparent lackiert.



FERRO "IRON DUST": speciale finitura color "grigio antracite" con polvere di metallo e laccatura opaca.  
"IRONDUST" iron: special finish "anthracite-grey" with metal-powder and mat lacquer.  
"IRONDUST" Eisen: Ausführung im Sonderfarbton "Eisen / anthrazit" pulverbeschichtet, transparent lackiert.



FERRO "CORTEN" effetto OSSIDATO, cerato.  
"CORTEN" IRON, OXIDIZED effect, waxed.  
"CORTEN EISEN", OXIDIERTEM Effekt, gewachst.



RAL 1013  
Bianco perla - Oyster white - Perlweiß



RAL 3020  
Rosso traffico - Traffic red - Verkehrsrot



RAL 7037  
Grigio polvere - Dusty grey - Staubgrau

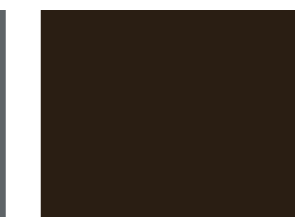

RAL 8019  
Marrone grigiastro - Grey brown - Graubraun



RAL 9001  
Bianco crema - Cream - Cremeweiß

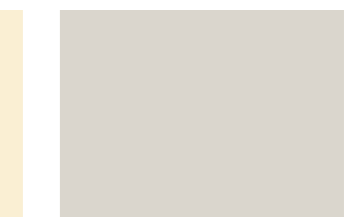

RAL 9002  
Bianco grigiastro - Grey white - Grauweiß



RAL 9005  
Nero intenso - Jet black - Tiefschwarz

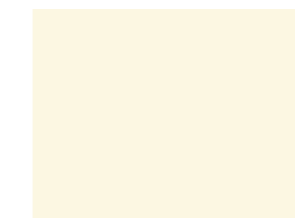

RAL 9010  
Bianco puro - Pure white - Reinweiß

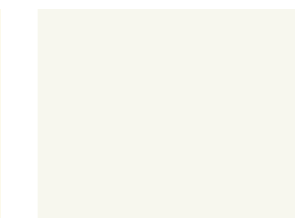

RAL 9016  
Bianco traffico - Traffic white - Verkehrsweiß

Sono possibili lievi difformità cromatiche dovute alla stampa tipografica.  
Slight colour differences may be found on the surface as a consequence of printing.  
Geringe Farbweichungen sind druckbedingt möglich.

## BASI E STRUTTURE IN METALLO E FINITURE - METAL BASES, STRUCTURES AND FINISHES METALLSTRUKTUREN, TISCHBEINE UND OBERFLÄCHEN

FERRO NATURALE e FERRO "CORTEN" OSSIDATO: alcuni prodotti della Collezione Riva 1920 sono realizzati con la base o struttura in lamina o tubolare di ferro naturale grezzo non tinto. Il ferro viene solo lavato con speciali detergenti neutri e successivamente rifinito a olio, oppure laccato trasparente opaco, oppure ossidato e cerato. Eventuali segni, piccoli graffi o aloni presenti sulla superficie delle gambe e delle strutture in ferro sono elementi tipici di un prodotto in metallo forgiato in altoforno e mantenuto grezzo senza alcuna verniciatura coprente. Eventuali ossidazioni della gamba sono altresì caratteristiche tipiche del ferro naturale. Per evitare l'effetto dell'ossidazione è sufficiente pulire periodicamente la gamba in ferro con il nostro olio del set di manutenzione RIVA 1920.

BASE IN FERRO COLORATO: a richiesta, se non diversamente indicato, è possibile richiedere la base in ferro verniciato opaco nelle tonalità di colore del campionario RAL o finitura IRONDUST.

NATURALLY COLOURED IRON and "CORTEN" OXIDIZED effect: some products of the RIVA 1920 Collection feature bases and structures made of natural plate or tubular iron. The base is first cleaned with specific neutral detergents and then finished with oil or mat transparent or oxidized. Any marks, little scratches or discolorations on the surface of the iron legs are typical features of any blast furnace-forged iron products not coated with paint. Similarly, any signs of oxidation on the legs are typical features of natural iron. In order to avoid the unaesthetic effects of oxidation, we advise to periodically clean the iron legs with the oil provided in the Maintenance Kit.

IRON STRUCTURES and BASES COATED WITH PAINT: iron bases and structures coated with opaque RAL paints or IRONDUST finish can be purchased upon request.

STRUKTUR / BASIS AUS NATÜRLICHEM EISEN / "CORTEN EISEN" OXIDIERTEM Effekt: Einige Produkte der RIVA 1920 Kollektion sind mit Strukturen aus natürlichem ungefarbtem Roheisen oder Roheisen transparent lackiert oder mit oxidiertem Effekt, gefertigt. Die Struktur wird nur mit speziellen neutralen Reinigungsmitteln gereinigt und anschließend auf natürliche Basis mit Öl vollendet. Eventuelle Zeichen, kleine Kratzer oder Schattierungen an den Tischbeinen aus Eisen sind typische Merkmale für ein Produkt aus in Hochofen geschmiedetes Roheisen, ohne zusätzliche Verwendung von Lacken. Eventuelle Oxidationen an den Tischbeinen sind weitere typische Merkmale vom unbehandelten natürlichen Eisen. Um die Auswirkung von Oxidationen zu vermeiden, ist es empfehlenswert, die Tischbeine regelmäßig mit unserem Pflegeset auf Ölbasis zu reinigen.

STRUKTUR AUS LACKIERTEM EISEN: Auf Anfrage, und wenn angegeben mit entsprechenden Aufpreis, ist die Eisenstruktur mit Mattlackierung in den "RAL"-Farbtonen oder "IRONDUST" Ausführung verfügbar.

# Riva1920 Showroom



Il nuovo Showroom Riva1920: un ambiente di circa 1200 mq, che esalta tutte le finiture esposte e destinato ad accogliere i visitatori che vorranno toccare con mano la qualità Riva. **Entrata libera.**

The new Riva 1920 showroom is a spacious area of about 1200 sq metres, where the essence and uniqueness of Riva 1920's products is enhanced. It is open to anyone interested in experiencing first-hand the Riva 1920's world. **Free entrance.**

Riva 1920 Ausstellung: neue Ausstellungsfläche auf über 1200 m<sup>2</sup> wo die Neuheiten unserer Kollektion präsentiert werden. Hier haben die Kunden die RIVA Qualität zum anfassen. **Freier Eintritt.**

**Riva1920**  
**Museo del legno**  
 Museum of wood  
 Holzmuseum



Al piano superiore, si trova il Museo del Legno, dove vengono proposti oltre 2000 macchine e utensili storici per la lavorazione del legno.

The top floor houses the Museum of Wood, which houses a display of over historic 2000 woodworking machines and tools.

Im oberen Stockwerk befindet sich das Holzmuseum, in dem über 2.000 historische Maschinen und Handwerkzeuge zur Bearbeitung von Holz ausgestellt sind.



**RIVA1920**  
 MADE IN ITALY

RIVA  
 Industria Mobili SPA  
 T. 0039 031 73 30 94  
 F. 0039 031 73 34 13  
 E. riva1920@riva1920.it

Museo del Legno  
 Show Room Riva1920  
 Via Milano, 110  
 22063 Cantù (Co) Italy

Sede  
 Unità Produttiva 1  
 Via Milano, 137  
 22063 Cantù (Co) Italy

Unità Produttiva 2  
 Via Genova, 13  
 22063 Cantù (Co) Italy

Unità Produttiva 3  
 Via Como, 74  
 22066 Mariano Comense (Co) Italy

RIVA Farm  
 22060 Cucciago (Co) Italy



[www.riva1920.it](http://www.riva1920.it)



Art-Direction: Terry Dwan  
 Concept: Terry Dwan con Claudia Caponnetto  
 Foto: ObiettivoV - Studio Eleven - Enrico Colzani  
 Stylist: Elena Riva, Marika Riva  
 Grafica: [www.studiograficonicoloso.it](http://www.studiograficonicoloso.it)  
 Stampa: La Grafica Cantù, Printed in ITALY 2014  
 Free catalogue, not for sale

1920  
LR<sup>®</sup>  
MADE IN ITALY